



WEST. Elektronik GmbH

more than just an electronics company

Founded in 1999 as a sole proprietorship we have evolved and established ourselves in the European market and beyond with the development and sale of special electronic modules for all - proportional controlled - hydraulic applications. The technologically-optimized solutions are based on many years of experience in the hydraulics field and are further developed in close cooperation with our clients.

We offer an extensive product line for all typical applications, from simple power amplifiers to p/Q regulated press control systems, up to multi-axis closed loop synchronization control systems. Custom developments for the clients are one of the strengths and many products for our well-known hydraulic manufacturers are being equipped with "brand labels". Premium quality, extremely short delivery times, flexibility, as well as fast assistance in case of emergencies - without the usual red tape – is what keeps the customers very satisfied.

Besides electronic products, W.E.St. Elektronik GmbH also offers competent support in the application of proportional control valves, starting with the calculation of the axis up to the simulation of the entire control system.

Application areas

The sophisticated design does not only address one specific application area but rather focuses on the universal use. Although, emphasis is put on industrial applications, however, the power amplifiers can be found in mobile as well as in marine applications (GL approval).

Products

The wide range of products can be divided into the following categories:

- Analog and digital power amplifiers, universally adaptable, for the control of various proportional control valves. The completely digital modules distinguish themselves through their high flexibility and fault diagnosis.
- Positioning modules, which are optimized for fast moving cycles and highly dynamic control systems.
- Pressure controlling with pressure valves, control valves and variable displacement pumps with simple and robust control behavior.
- Synchronization modules for synchronized control systems in bypass or as a synchronized position control system with integrated pressure limitation control (optional use).
- Control systems for various displacement and servo pumps.
- Fieldbus connections for the most of our control modules. The products support CAN Bus, Profibus, Profinet, EtherCAT and various Ethernet versions.

Services

In addition to selling our products, we also provide all essential services around them.

- Development of custom electronics according to your specification
- Production planning and electronics production
- Calculation and simulation of hydraulic systems
- Training for our standard products as well as training for special subjects

Contents

- | | |
|----|---------------------------------------|
| 2 | Information about the company |
| 4 | Overview over product groups |
| 5 | Modelcode explanation |
| 7 | Universal closed loop control modules |
| 11 | Position controls |
| 19 | PID and pressure controls |
| 27 | Synchronization controls |
| 33 | Pump controls |
| 37 | Power amplifiers |
| 49 | Overview WPC |
| 50 | Disclaimer |

Product groups



Universal and command signal modules

Command signal modules, digital programmable or via potentiometer, as well as standard closed loop control modules..



Power amplifiers

For proportional valves. Simple control of servo- and proportional valves. A favorable price and a simple handling have priority. Thereby the digital PAM-199-P is the most universal device with the largest range of functionality.



Position control modules

Various position control modules from simple modules for analog sensors up to axes controls with Profibus coupling, EtherCAT and ProfiNet.



Synchronization control modules

From bypass control up to multi axes synchronization and position control with Profibus or ProfiNet, we offer the complete range of solutions for different applications.



Pressure control modules

PID-pressure control modules for universal use with pressure valves or pumps as well as p/Q-control modules for volume flow control with pressure limitation control.



Pump control modules

These modules offer solutions especially for the requirements of variable displacement pumps. Possibilities for closed loop displacement control, open loop displacement control with additional pressure control (p / Q) or the combination of displacement control and pressure control are available. The power control or limit load control is available as an option.

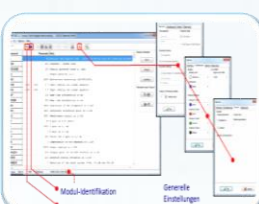

Software

Start-up software for fast and easy parameterizing of our digital control modules.

Modelcode explanation

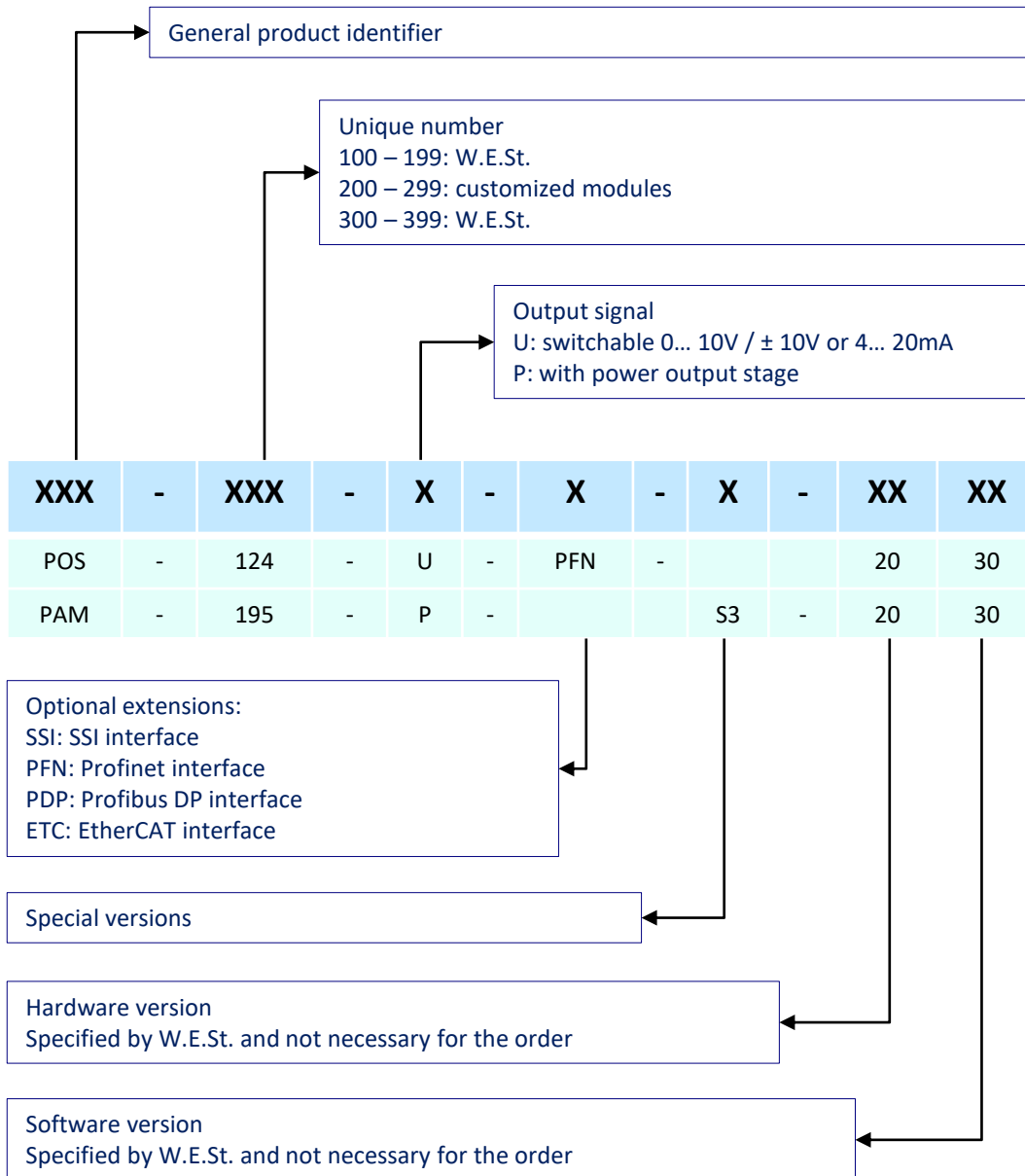

WEST. Elektronik GmbH

Universal function modules

Demand value modules, digital programmable or via potentiometer adjustable, and standard control modules

DSG-111 Digital command signal module

DSG-164 Command signal module

DSG-111

Digital demand value module, alternatively with power output stage

This electronic module was designed to control hydraulic proportional valves. 16 programmable demand values and relating ramp times are selectable by four digital switching inputs (binary coded). Additionally, a scalable analog command input with own ramp function is available, too.

Alternatively, a 4Q-ramp can be parameterized. The ramp generator is realized with optional jerk limitation which allows flexible adjustments depending on the applications and soft behavior.

A programmable function allows linking the analog input signal and the internal demand values together by different mathematical operations.

This module is adaptable to nearly all proportional valves by deadband compensation as step function for characteristic linearization.

Proportional valves with integrated or external electronics can be controlled by the universal analog output of the standard device. For controlling valves without electronics, the extended version with power stage is provided.

Typical applications: rapid traverse and creeping speed, selectable velocities and pressure values, flow curve adjustments, ramp generation and analog signal monitoring.

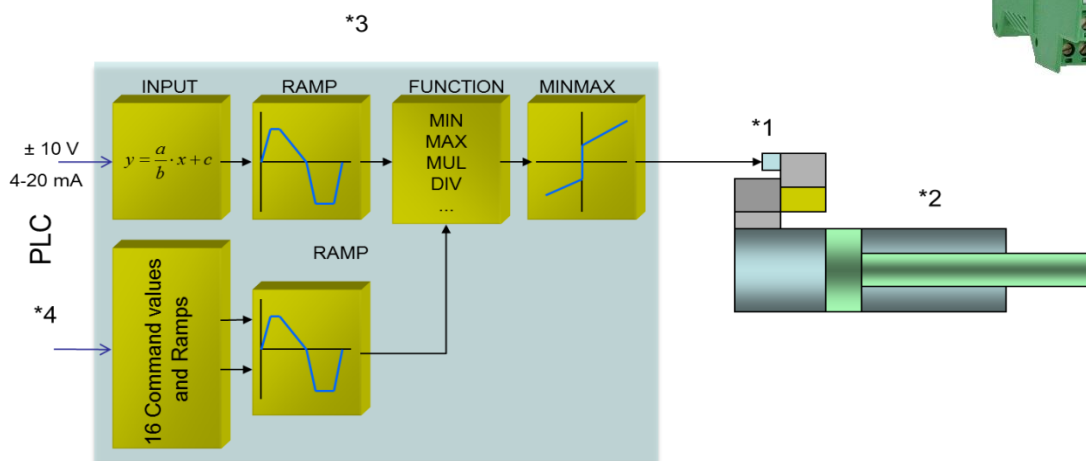

- *1 Proportional valve (or control valve):
- *2 Hydraulic cylinder
- *3 DSG-111-U control module
- *4 Interface to PLC with analog and digital signals

- ✓ 16 selectable demand values
- ✓ Four quadrant ramp function or 16 selectable ramp times
- ✓ Jerk free ramp generating
- ✓ Simple and intuitive parameterizing of the analog input
- ✓ Analog input and demand values are combinable with various mathematical functions
- ✓ Diverse parameters for valve adaptation
- ✓ Nominal output current up to 2.6 A in P-version

Versions	Model code
Standard module	DSG-111-U
Standard module with power output stage	DSG-111-P

DSG-164

Demand signal module

This module is a demand signal module. Via four digital inputs, four by potentiometer adjustable demand values can be selected. For the supply of external potentiometers a reference voltage (10 V) is available. Another digital input allows switching the polarity of the output signal. Only one value can be active at the same time. If more than one input is activated, the highest priority is selected. If there is no input activated, an external voltage signal can be connected through to the output. This feature enables cascading of those modules.

Typical applications: analog generating of demand values by digital inputs.

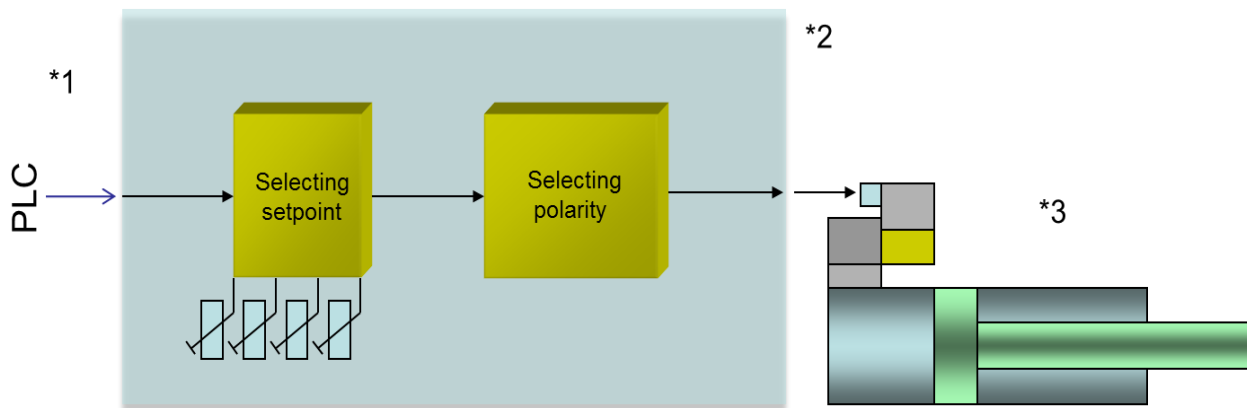

- *1 Interface to PLC with digital signals
- *2 Demand signal module DSG-164
- *3 Proportional valve

- ✓ Demand signals adjusted by potentiometers
- ✓ Digital selection of the values
- ✓ Differential output with polarity switching
- ✓ Reference voltage output
- ✓ Cascadable

Versions	Model code
Standard module	DSG-164-30

WEST Elektronik GmbH

Position controls

Various position control modules from simple versions for analog sensors up to axis control modules with fieldbus coupling

- POS-123 Universal positioning controller, alternatively with power output stage, Profinet or SSI interface
- POS-124 Two-axis positioning- and synchronization controller with Profibus DP resp. Profinet IO coupling and SSI Sensor interface
- PPC-125 Universal axis controller, with Profibus, position control, pressure control and SSI interface
- UHC-126 Universal axis controller (Position control and pressure control) with Profinet, Profibus or EtherCAT
- POS-323 Digital positioning controller with integrated commissioning assistant

POS-123

Universal positioning module, optionally with power output stage, Profinet or SSI interface

This electronic module has been developed for controlling hydraulic positioning drives. Proportional valves with integrated or external electronics can be controlled with the universal analog output.

The internal profile generation is optimized for stroke-dependent deceleration or the NC control mode. The controller and the controller settings are adapted to typical requirements and thus permit rapid and uncritical optimization of the control behavior. The optimized control function offers a high degree of precision together with high stability for hydraulic drives. The movement cycle is controlled via the external position and speed inputs; in SDD mode as a particularly robust and easy-to-parameterize control and in NC mode via the internal profile generator.

Alternatively, the P version is available with an integrated power output stage. The advantage of the integrated power output stage is founded in the integrated control behavior without additional dead times. This allows higher dynamics respectively a higher stability.

The SSI extension is available for use with digital sensors. Sensors with a resolution of one μm can be used for very high position accuracy.

Typical applications: general positioning drives, fast transport drives, handling systems and speed-controlled axes.

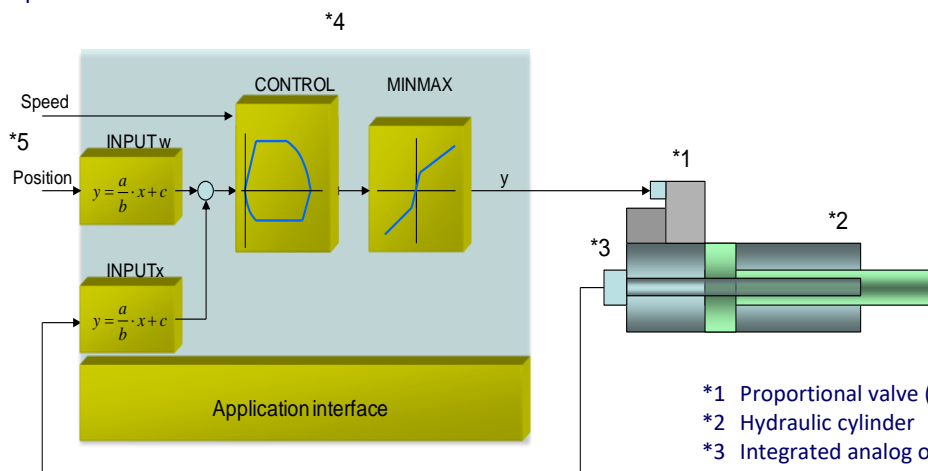

- *1 Proportional valve (or control valve):
- *2 Hydraulic cylinder
- *3 Integrated analog or SSI position sensor (alternatively also with external position sensor)
- *4 POS-123-* control module
- *5 Interface to PLC with analog and digital signals

- ✓ Analog or digital SSI position sensors
- ✓ Command inputs for analog position and speed
- ✓ Simple and intuitive scaling of the sensor
- ✓ Internal profile definition by acceleration, velocity and deceleration
- ✓ Principle of stroke-dependent deceleration for fast and robust positioning
- ✓ NC profile generator for constant speed
- ✓ Expanded closed loop control technology with PT_1 control, drift compensation and fine positioning
- ✓ Optimal use with overlapped proportional valves and with zero lapped control valves

Versions	Model code
Standard module with universal analog output and analog sensor interface	POS-123-U
With integrated power output stage up to 2.6 A	POS-123-P
With Profinet interface and integrated power output stage up to 2.6 A	POS-123-P-PFN
With SSI sensor interface and 0... 10 V feedback monitoring output	POS-123-U-SSI
With 4... 20 mA feedback monitoring output	POS-123-U-SSI-S1

POS-124-U

Two-axis positioning and synchronization control module with integrated Profinet Io, EtherCAT resp. Profibus DP interface and SSI sensor interface

This electronic module has been developed for controlling two hydraulic positioning axes. Both axes can be driven independently or controlled in synchronous mode via Profinet / Profibus / EtherCAT.

The differential outputs are provided for the control of proportional valves with integrated or external electronics (with differential input). Alternatively, the output can be parameterized to 4... 20 mA. This module is designed for the use with analog position sensors 0... 10 V or 4... 20 mA (scalable) as well as digital SSI sensors.

The internal status and faults information are transmitted to the master controller. Additionally, the operational readiness is reported via a READY output

Typical applications: position control and/or synchronization control with hydraulic axes.



POS-124-U

Two-axis positioning and synchronization control module with integrated Profinet IO resp. Profibus DP interface and SSI sensor interface

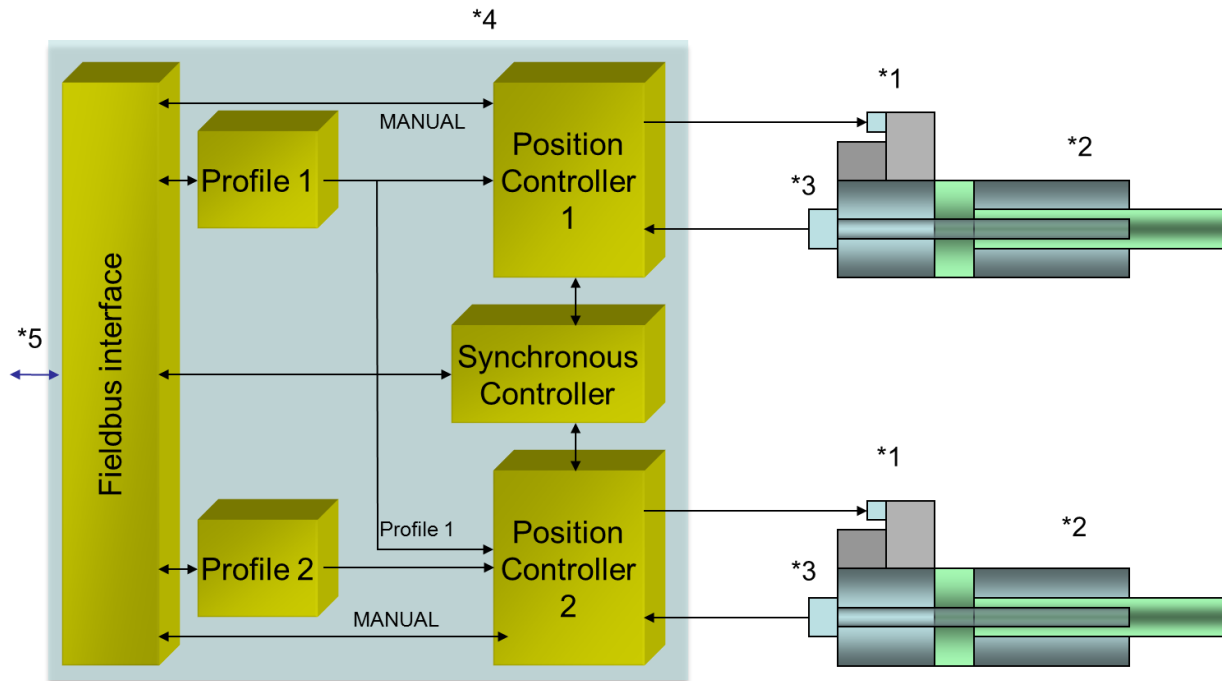

- *1 Proportional valve with integrated electronics
- *2 Hydraulic cylinder
- *3 Control module POS-124-U-PDP / PFN
- *4 Fieldbus interface
- *5 Position sensor

- ✓ Two independent positioning axes
- ✓ Can be combined for synchronized control
- ✓ Command parameter, actual position feedback, control and status byte via fieldbus (Profibus DP / Profinet IO / EtherCAT)
- ✓ SSI sensor interface with a resolution of 0.0001 mm or analog sensor interface (0... 10 V or 4... 20 mA)
- ✓ Simple and user-friendly sensor scaling
- ✓ Speed resolution of 0.005 mm/s
- ✓ Principle of stroke-dependent deceleration for a robust positioning
- ✓ NC profile generator for constant speed
- ✓ High-precision positioning
- ✓ Advanced position control with PT_1 controller, drift compensation and fine positioning
- ✓ Superimposed synchronization controller with PT_1 (optimal for hydraulic applications)
- ✓ Optimal use with zero lapped control valves
- ✓ Synchronization control in Master/Slave or average value mode

Versions	Model code
Standard module with Profibus DP interface	POS-124-U-PDP
Standard module with Profinet I/O interface	POS-124-U-PFN
Standard module with EtherCAT interface	POS-124-U-ETC

PPC-125-U-PDP

Universal axis controller with Profibus, position control, pressure control and SSI interface

This electronic module was created to control hydraulic axes by an integrated Profibus DP interface. The hydraulic axis can be driven as positioning control with digital stroke measuring by a universal SSI interface or an analog sensor.

In addition, a force or differential pressure control, which operates autonomously or as a pressure-limiting control function, is implemented.

Command signals and actual values are transmitted by a Profibus communication interface. Feedback are status information and actual values.

Parameterization is possible by our PC program WPC-300 with integrated oscilloscope function. Alternatively, defined parameters can also be adjusted via the Profibus interface.

Typical applications: positioning drives, fast transport drives, handling axes, forming machines with position and pressure control as well as feed drives.

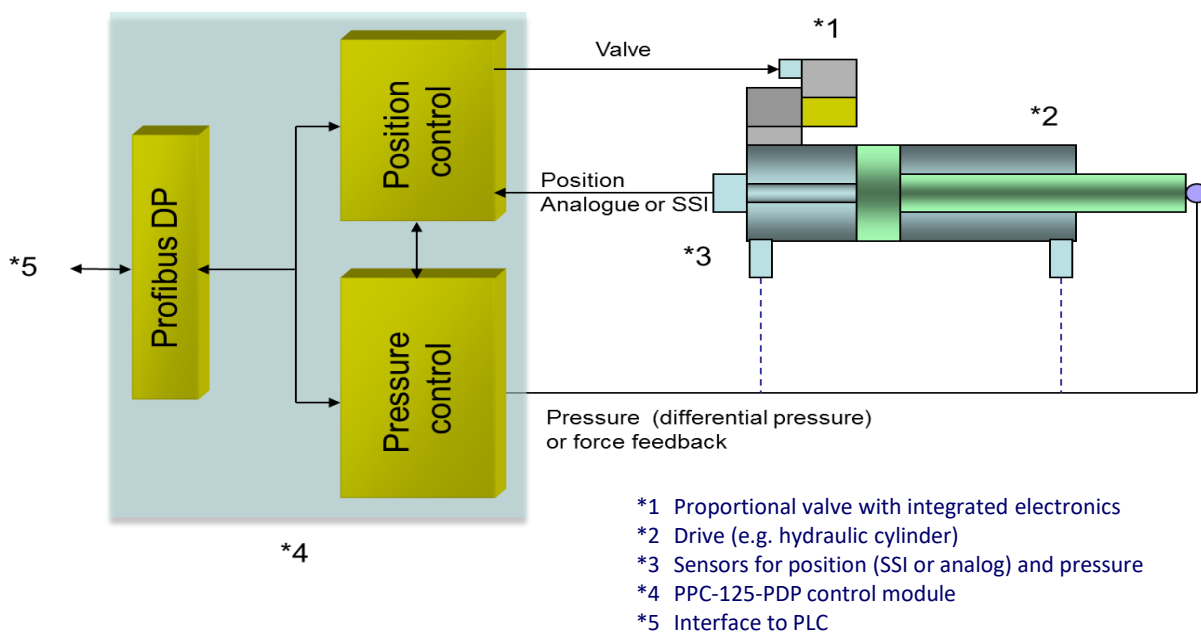

- ✓ Demand values, actual sensor values, control and status byte via fieldbus (Profibus DP)
- ✓ SSI or analog feedback sensors (0... 10 V or 4... 20 mA)
- ✓ Simple and intuitive scaling of the sensor
- ✓ Resolution of the position up to 1 μm (SSI interface)
- ✓ Speed resolution 0.005 mm/s
- ✓ Speed profiles
- ✓ PQ-control function with pressure limitation
- ✓ Principle of stroke-dependent deceleration for fast and robust positioning
- ✓ NC profile generator for constant speed
- ✓ High-precision positioning
- ✓ Rapid/creep speed positioning
- ✓ Expanded closed loop control technology with PT_1 controller, drift compensation and fine positioning
- ✓ Optimal use with zero lapped control valves

Versions

Standard module

Model code

PPC-125-U-PDP

UHC-126-U

Universal axis controller with positioning and pressure control

This electronic module was developed for controlling hydraulic axes via an integrated Profinet, Profibus or EtherCAT fieldbus interface.

The hydraulic axis can be driven as positioning control with digital stroke measuring (SSI interface) or by an analog sensor.

In addition, a force or differential pressure control is implemented. This can be used autonomously or as a pressure-limiting control.

Command values and control signals are transmitted to the module by fieldbus. Feedback are status information and actual values.

The differential output is designed for the control of proportional valves with integrated or external electronics (differential input). Alternatively, a 4 ... 20 mA current signal can also be parameterized.

Internally the system is monitored for several failures and states. The READY message is available as a fieldbus signal and digital output.

The parameterization is realized via a USB interface in combination with our PC program WPC-300 with integrated oscilloscope function. Alternatively, defined parameters can be modified via the Profinet interface.

Typical applications: positioning drives, fast transport drives, handling axes, forming machines with position and pressure control as well as feed drives.

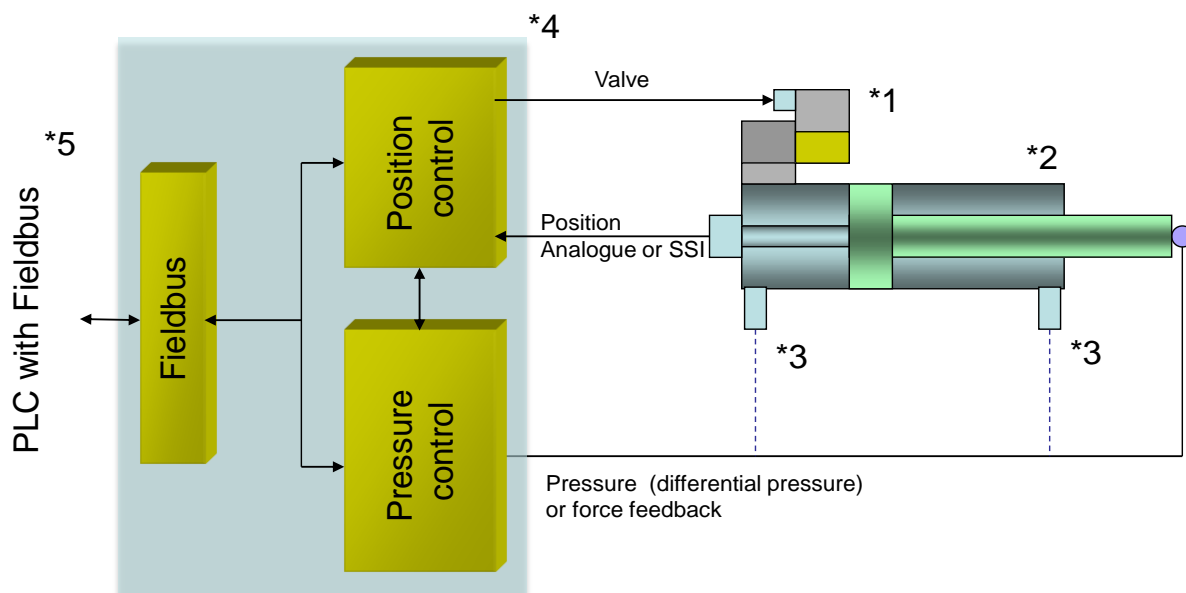

- *1 Proportional valve with integrated electronics
- *2 Drive (e.g. hydraulic cylinder)
- *3 Sensors for position (SSI or analog) and pressure
- *4 UHC-126 control module
- *5 Interface to PLC

UHC-126-U

Universal axis controller with positioning and pressure control

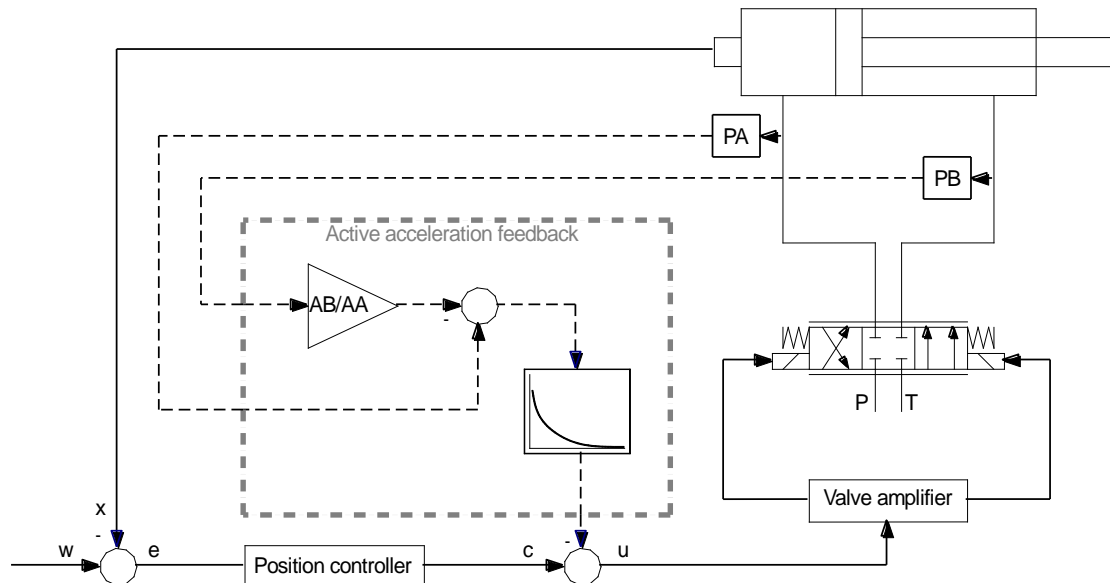

Position control with acceleration feedback via the differential pressure

- ✓ Demand values, actual values feedback, control and status byte via fieldbus (Profibus DP)
- ✓ SSI or analog feedback sensors (0... 10 V or 4... 20 mA)
- ✓ Resolution of the position up to 1 μm (SSI - interface)
- ✓ Speed resolution 0.005 mm/s
- ✓ Positioning mode: stroke-dependent deceleration or NC mode with internal profile generator
- ✓ Rapid/creep resp. creep/rapid speed positioning is integrated
- ✓ Alternatively it can be switched over to continuous command signal transition
- ✓ Pressure control function also as pressure-limiting control (differential pressure control or force control)
- ✓ Enlarged control technology with PT_1 filter, drift compensation for optimal zero point adjustment, fine positioning for compensation of load-dependent positioning deviations, feed forward to reduce the following error, acceleration feedback (by measuring the differential pressure) to improve the dynamic behavior in case of low dynamics drives
- ✓ Optimal use with overlapped proportional valves and zero lapped control valves

Versions	Model code
Standard module with Profinet interface	UHC-126-U-PFN
Standard module with Profibus interface	UHC-126-U-PDP
Standard module with EtherCat interface	UHC-126-U-ETC

POS-323

Digital positioning control unit with integrated automatic commissioning assistant

Basis of this device is the standard positioning controller POS-123. The integrated commissioning assistant was made for an easier start-up of a hydraulic positioning control. Analyzing and automatic parameterizing of several settings should help the user to adjust the system in a shorter time. Intention of this functionality is getting a system ready to work in a stable way as quick and easy as possible.

The assistant provides different functions, which can be executed separately, combined or in complete scope of operation. Among those functions are detecting and parameterizing the usable working stroke, the polarity and a possible offset, as well as a deadband of the valve and the usable maximum speed. By means of a dynamic investigation, furthermore the control parameters can be set.



Automatic functions:

- Sensor scaling
- Deadband compensation (in case of overlapped valves)
- Zero point adjustment (in case of zero overlapped valves)
- Measuring of the maximum speed for each direction
- Measuring of the response of the system to set the closed loop control parameter

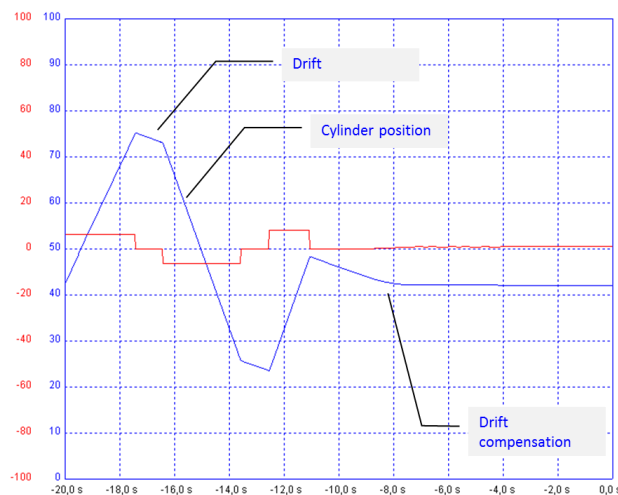

- ✓ Assistant system as start-up support
- ✓ Only basic data have to be parameterized
- ✓ Time saving up to the running axis
- ✓ For a stable behavior without parameterizing the controller itself
- ✓ Scope of operation of the assistant system is selectable

Versions

Standard module with power output stage

Model code

POS-323-P

WEST Elektronik GmbH

PID / pressure controls

PID pressure control modules for general use with pressure valves or variable displacement pumps and p/Q control modules for flow control and closed loop pressure limitation control

- PID-131 Standard PID control module
- PQ-132 p/Q control, pressure limitation control for hydraulic axes
- MDR-133 Pressure control
- MDR-137 Pressure control with integrated power amplifier
- MDR-337 Pressure control with integrated power amplifier and automatic commissioning assistant
- SCU-138 Speed control with power output stage

PID-131-U

Standard PID controller

This module was developed for general controlling of dynamic systems. The controller structure is designed as a classic PID compensator with a short cycle time of 1ms.

It is possible to choose out of different sensor and command signal types and polarities as 20... 4 mA, 4... 20 mA, 0... 10 V or 10... 0V. More special input signals can be freely adapted via a mathematical scaling function.

The output signal is available as an active differential signal for the direct connection of valves with integrated electronics. A current signal is parameterizable here, too.

For the controller, the user may choose between two parameter sets.

REMOTE CONTROL for commissioning is possible.

Typical applications: dynamic PID compensator for force, pressure and speed control.

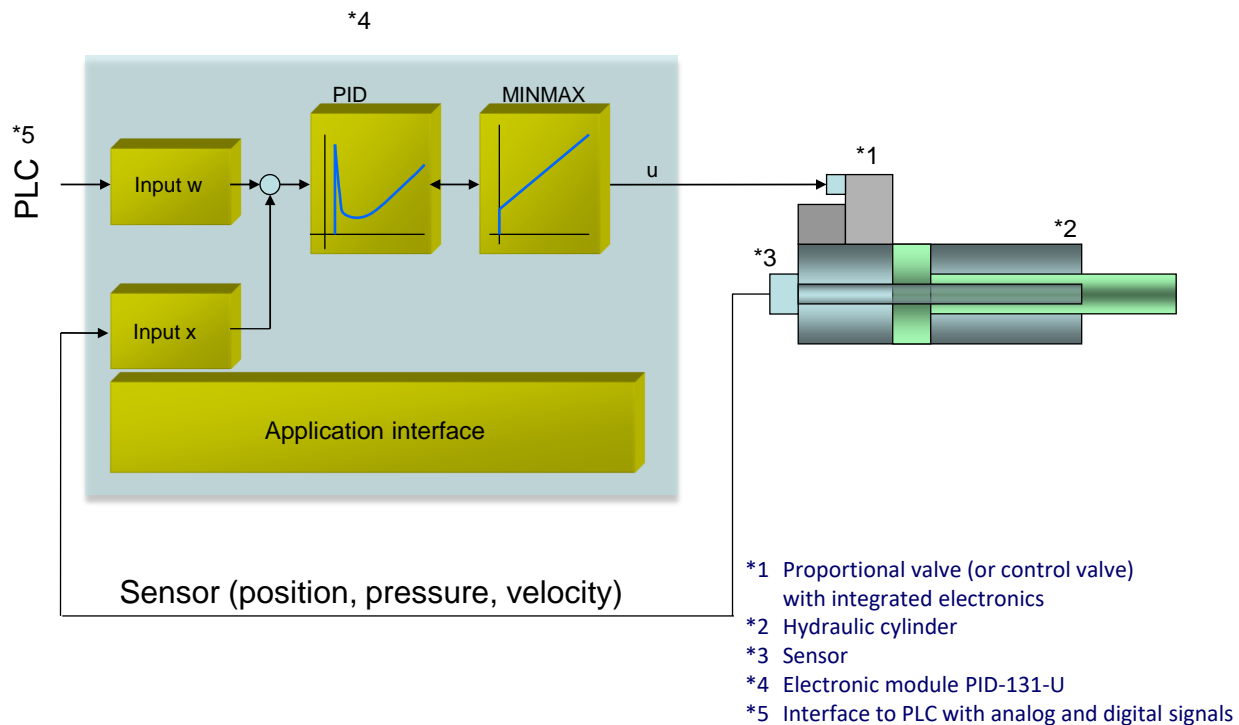

- ✓ Analog command and feedback values (0... 10 V or 4... 20 mA)
- ✓ Ramp function on the command value
- ✓ Universal controller structure
- ✓ Pressure dependent activation of the integrator by pre-set threshold value for preventing pressure overshoots
- ✓ Application orientated parameter settings
- ✓ Universal output for several analog signals
- ✓ REMOTE CONTROL mode via serial interface

Versions	Model code
Standard module	PID-131-U

PQ-132-U

p/Q controller, pressure limitation controller for hydraulic axes

This module was developed for controlling pressure and force of hydraulic drives, worked out as a classical p/Q controller (flow control with closed loop pressure limitation function).

The command values are set via analog signals or as fixed parameters and the module is controlled with digital inputs.

The output signal is available as an active differential output for direct connecting of control valves with integrated electronics. Alternatively, a current output can be parameterized.

The control loop works with a cycle time of 1 ms (adjustable). The controller is equipped with two sets of parameters, which can be switched in case of critical applications with different operating points. Programmable are the standard PID control parameters and an additional activation threshold for the integrator. The system is monitored internally for various errors. These are indicated by the digital output signal and the corresponding LED.

Typical applications: electronic 3-way pressure control, pressure limitation control and differential pressure control.

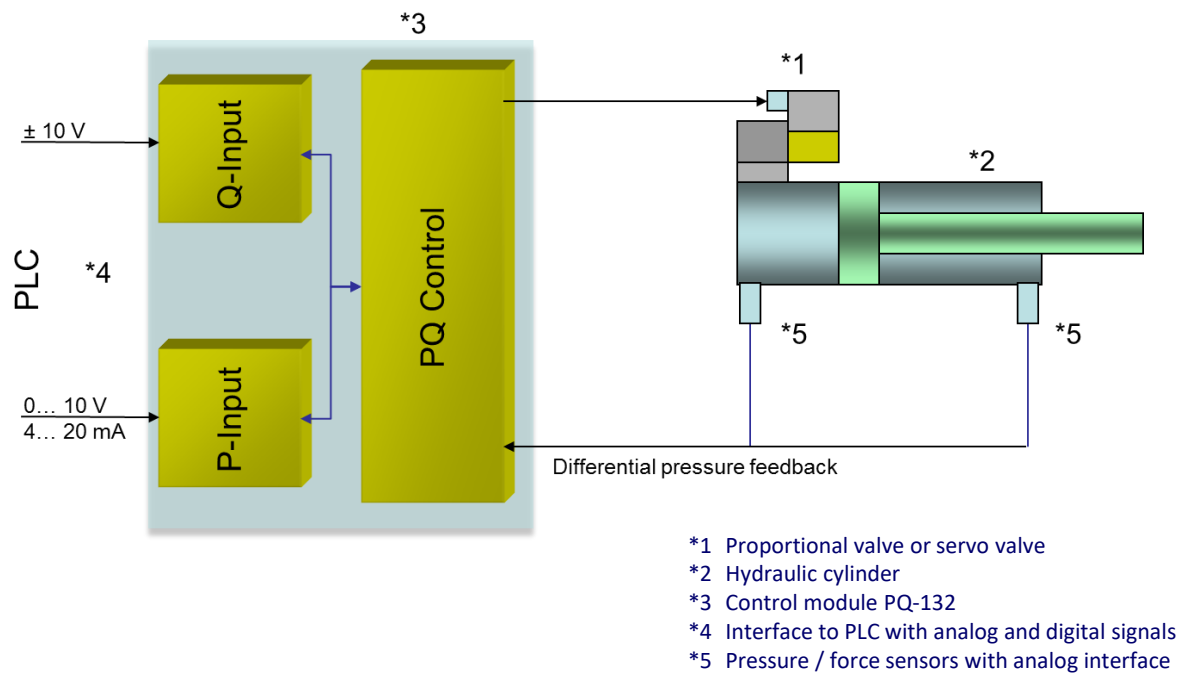

- ✓ Analog **Q** and **P** command values
- ✓ Simple and intuitive scaling of the sensors
- ✓ Classical p/Q controller with pressure limitation (automatic switch over)
- ✓ PID-controller with two switchable parameter set
- ✓ Ramps for pressure up and down
- ✓ Pressure control with one sensor
- ✓ Differential pressure control with two pressure sensors

Versions	Model code
Standard module	PQ-132-U

MDR-133

Pressure control module

This module was developed for control of pressure and force in hydraulic systems. The control structure is optimized for pressure closed-loop control systems with typical pressure valves.

The controller works in a bypass control function, where the input signal is linked directly to the control output (pressure valve) and the PID compensator has to control the linearity deviations only. In many cases, the optimization can be carried out without further test equipment (only a pressure sensor is needed).

The output signal is available as 0... 10 V or 4... 20 mA signal for the direct connection of valves with integrated electronics. External amplifiers and our power plug can be used, too.

Alternatively, the controller is available with an integrated power output stage. The advantage of the integrated power output stage is founded in the integrated control behavior without additional dead times. This allows higher dynamics and higher stability respectively.

Typical applications: pressure control with pressure relief valves and/or pressure reducing valves.

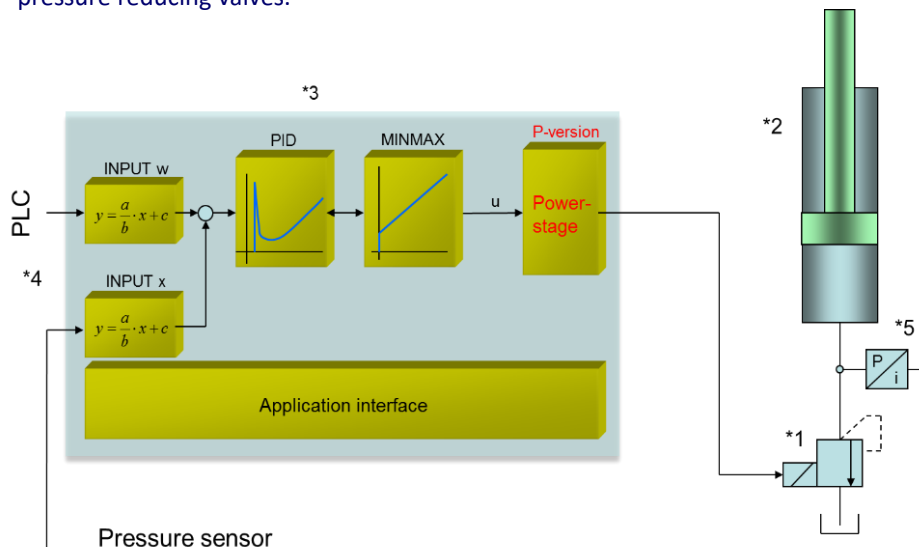

- *1 Pressure relieve valve (option: pressure controlled servo pump)
- *2 Cylinder / actuator
- *3 MDR-133 pressure controller
- *4 Interface to PLC
- *5 Pressure or force sensor

- ✓ Analog pressure command and actual values
- ✓ Special pressure control concept for pressure reducing and relief valves
- ✓ Optimized controller for pressure closed loop control
- ✓ Integrated functions to prevent pressure overshoots
- ✓ Simple optimizing of the controller
- ✓ Ramps for pressure up and down
- ✓ Standard USB interface

Versions	Model code
Standard module	MDR-133-U
Standard module with power output stage	MDR-133-P

MDR-137-P

Pressure control module with integrated power amplifier

This module has been developed for controlling pressure and force (and optionally the speed) in hydraulic systems. A power stage for proportional valves is integrated. Various parameter settings allow an optimal adaptation to the respective valve. The control circuit operates with a control cycle time of 1 ms and the integrated power stage with a cycle time of 0.125 ms for the solenoid current control.

The demand and the actual value are read in via a 0... 10 V signal (optionally 4... 20 mA with cable break monitoring). The ramp function and the PID controller are universally applicable. The output current is closed loop controlled and thus independent of the supply voltage and the solenoid resistance. The power output stage is monitored for cable break and overcurrent (short circuit) and switches off in the event of a fault.

Programmable are the standard PID control parameters and a threshold value for the integrator limitation and activation as well as various parameters for valve adaptation.

Typical applications: pressure control with pressure valves and servo pumps as well as speed control with analog speed controllers (speedometer).

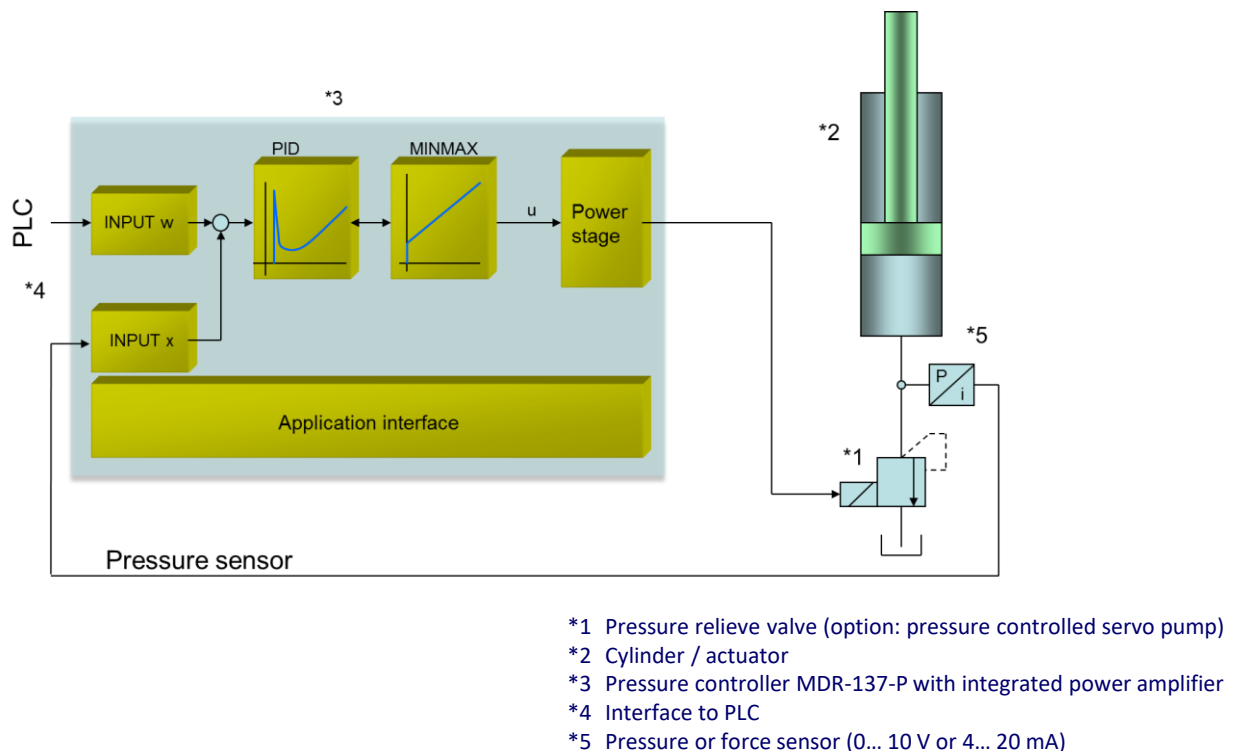

- ✓ Control of pressure reducing and pressure control valves
- ✓ Compact housing
- ✓ Digital reproducible adjustments
- ✓ Universal PID compensator
- ✓ Free parameterization of ramps, MIN and MAX, DITHER (frequency, amplitude) and PWM frequency
- ✓ Nominal current up to 2.6 A

Versions	Model code
Standard module	MDR-137-P

MDR-337-P

Pressure control module with integrated power amplifier and automatic commissioning assistant

This module has been developed for controlling pressure and force (and optionally speed, too) in hydraulic systems. The controller structure is optimized for pressure closed-loop control systems with typical pressure valves (pressure reducing or pressure relieve valves and also for pressure controlled servo pumps). An integrated power stage and high dynamic control loops offer a simple and powerful solution.

The control loop is designed as bypass control function, where the input signal is linked via a control parameter directly to the control output (pressure valve) and the PID compensator has to control the linearity deviation only. In many cases the optimization can be carried out without further test equipment (only a pressure sensor is needed).

The output signal is available as an integrated PWM power signal from 0,5 to 2,6 A. This output is over-current and short-circuit protected.

Because of the easy handling a very short training period is guaranteed.

Typical applications: General pressure control with pressure valves (direct or via a variable displacement pump).

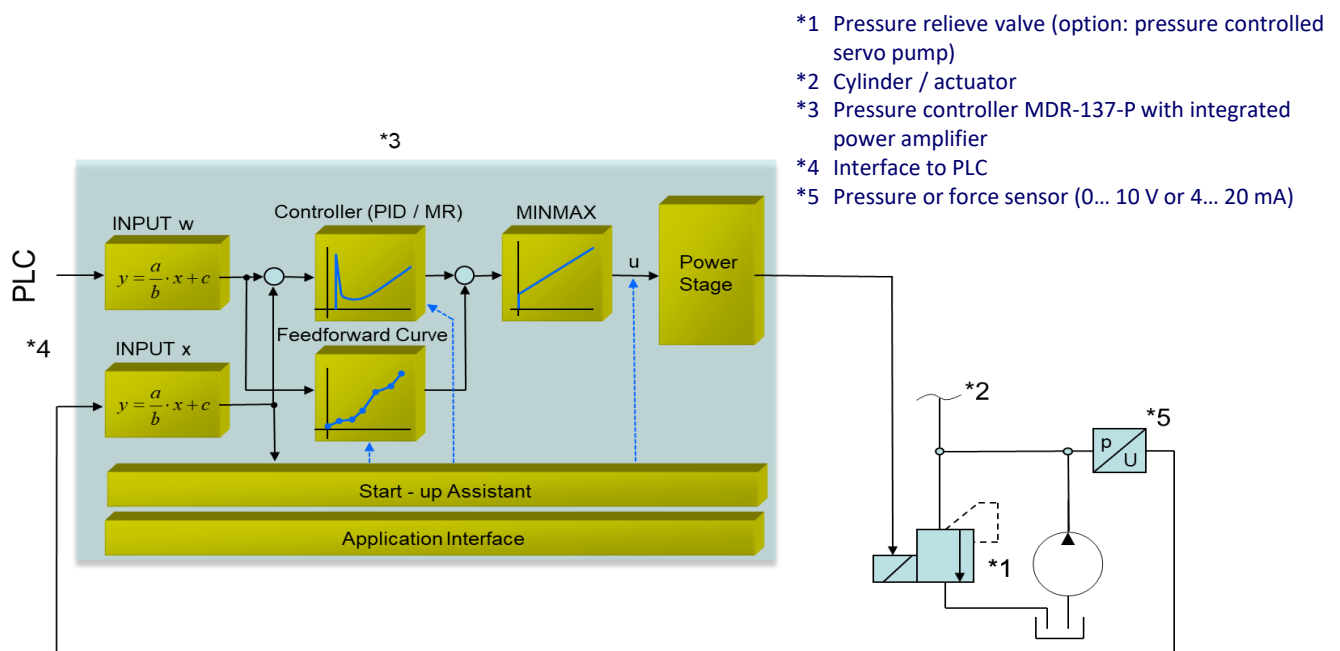

- ✓ Activation of pressure reducing valve and pressure control valve
- ✓ Compact housing
- ✓ Digital reproducible adjustments
- ✓ Universal PID actuator
- ✓ Alternative: MR - controller activatable, patented and particularly robust solution
- ✓ Commissioning assistant for determining an optimum feedforward characteristic and for dynamic controller adjustment
- ✓ Free parameterization of ramps, MIN and MAX, DITHER (frequency, amplitude) and PWM frequency
- ✓ Nominal current from 0,5 A up to 2,6 A

Versions	Model code
Standard module with automatic commissioning assistant	MDR-337-P

SCU-138-P

Speed control unit with integrated power stage

This module was developed for controlling a universal closed loop control system for speed and velocity control. A power stage for proportional valves is integrated. Various parameter settings allow an optimal adaptation to the corresponding valve. The controller runs with a loop time of 1 ms and the power stage with 0.125 ms for the current control.

The command value is set via an analog input signal in the range of 0... 10 V or 4 ... 20 mA. Optionally, a PWM input signal can be used. Alternatively, a command value can be programmed internally (fixed speed control for generators). The ramp function and the PID controller are universally usable. The output current is closed loop controlled and therefore independent of the supply voltage and the solenoid resistance. The power output stage and current input signals are monitored for cable break and switch off in case of detected errors.

Programmable are the standard PID control parameters and a threshold value for integrator limitation and activation as well as various parameters for the valve adaptation.

Typical applications: speed control with pulse generators.

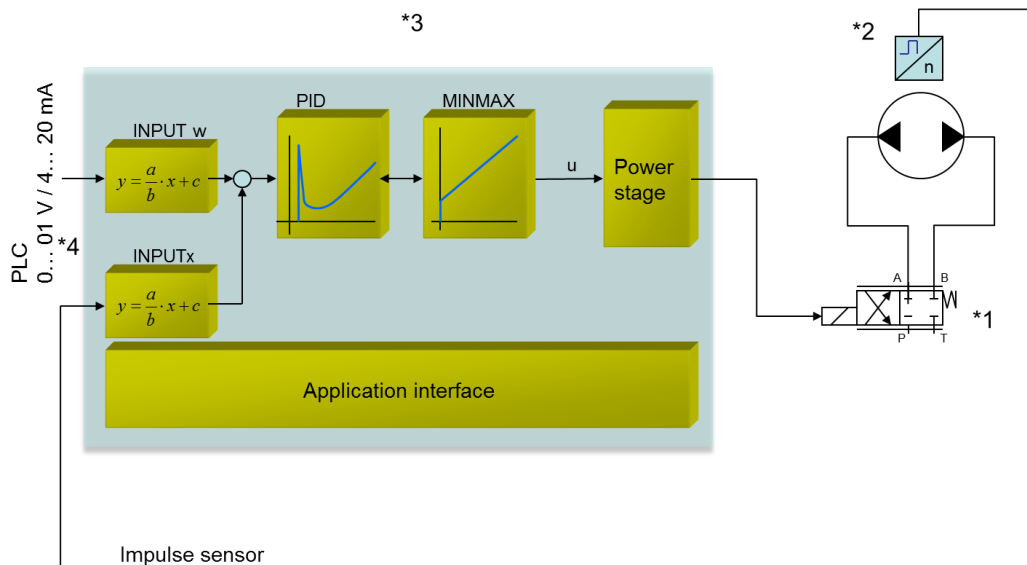

- *1 Proportional valve
- *2 Pulse generator for sensor signal
- *3 Speed control unit SCU-138-P
- *4 Interface to PLC

- ✓ Universal speed control unit
- ✓ Compact housing
- ✓ Digital reproducible adjustments
- ✓ Free scaling of the analog command input
- ✓ Universal PID controller
- ✓ Controlling of proportional valves with one or two solenoids
- ✓ Direct connection of pulse generators
- ✓ Free parameterization of ramps and the power stage
- ✓ Output current up to 2.6 A
- ✓ Adaptable to all standard proportional valves

Versions	Model code
Standard module	SCU-138-P

WEST Elektronik GmbH

Synchronization

From bypass control to multi-axis synchronizing and positioning control with Profibus and CAN Bus, we offer a complete range of solutions for a wide range of applications

CSC-151	Synchronization control module for two cylinders in bypass, alternatively with power output stage
CSC-152	Universal positioning and synchronization module, alternatively with power output stage
CSC-156	Synchronization system module with pressure limitation control, SSI interface and Profibus coupling for 2 - 4 axes
UHC-126-U-PFN-S2	Axis control module with universal positioning, pressure limitation control and Fieldbus interface, special version for distributed synchronization control

CSC-151

Synchronization control module for the synchronization of two cylinders in bypass, optionally available with power output stage

This electronic module has been developed for the control of hydraulic synchronization systems. The typical synchronization accuracy is about 0.1 % to 1 % of the sensor length (depending on the hydraulic system).

With this control concept, no absolute positions are approached, rather the synchronization of two axes is realized by a proportional directional valve arranged in bypass. A minimum of synchronization is achieved, for example via a flow divider valve or a gear divider. The proportional valve operates in parallel to compensate the specific deviation of the divider (typically 2... 10 %).

This kind of synchronization control is extremely stable and simple to use. Proportional valves with integrated electronics and external power amplifiers can be driven by the universal analog output. For valves without electronics this controller is also available with an integrated power stage.

Typical applications: synchronization control with bypass valve.

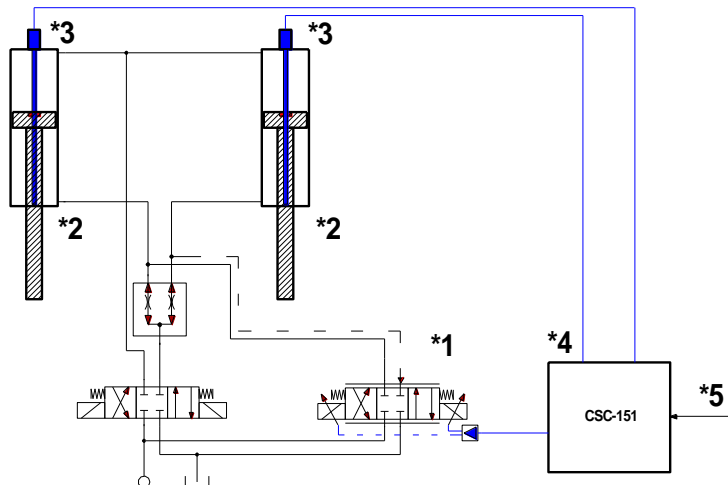

- *1 Proportional valve for deviance compensation
- *2 Hydraulic cylinder
- *3 Analog position sensor, integrated or external
- *4 Control module CSC-151
- *5 Interface to PLC with analog and digital signals

- ✓ Analog feedback sensors
- ✓ Simple and intuitive scaling of the sensors
- ✓ Simple and inexpensive system with only one proportional directional valve
- ✓ Principle of bypass control (parallel to the flow divider)
- ✓ A basic synchronization is ensured by the flow divider
- ✓ Expandable to up to 4 axes with 3 closed loop control modules
- ✓ Optimal use with overlapped proportional valves and with zero lapped control valves



Versions	Model code
Standard module	CSC-151-U
Standard module with power output stage	CSC-151-P

CSC-152

Universal positioning and synchronization module, alternatively with power output stage

This electronic module has been developed for controlling hydraulic positioning / synchronization drives. Proportional valves with integrated or external electronics can be controlled with the universal analog output.

The internal profile generation is optimized for stroke-dependent deceleration or NC control. The controller and its settings are adapted to the typical requirements and thus offer rapid and uncritical optimization of the control behavior. The time-optimized control function offers a high degree of precision together with high stability for hydraulic drives. The movement cycle is controlled via the external position and speed inputs. The high resolution of the analog signals ensures good positioning behavior.

The synchronization control works as a second overriding velocity / position controller. Deviations between the axes will be compensated by adjusting the speed of the slave axis (or both axes in master/master mode). The speed of the axes can be limited with the external analog speed input.

Alternatively, this controller is available with an integrated power output stage.

Typical applications: synchronization and positioning of two axes (up to four axes in master slave mode).

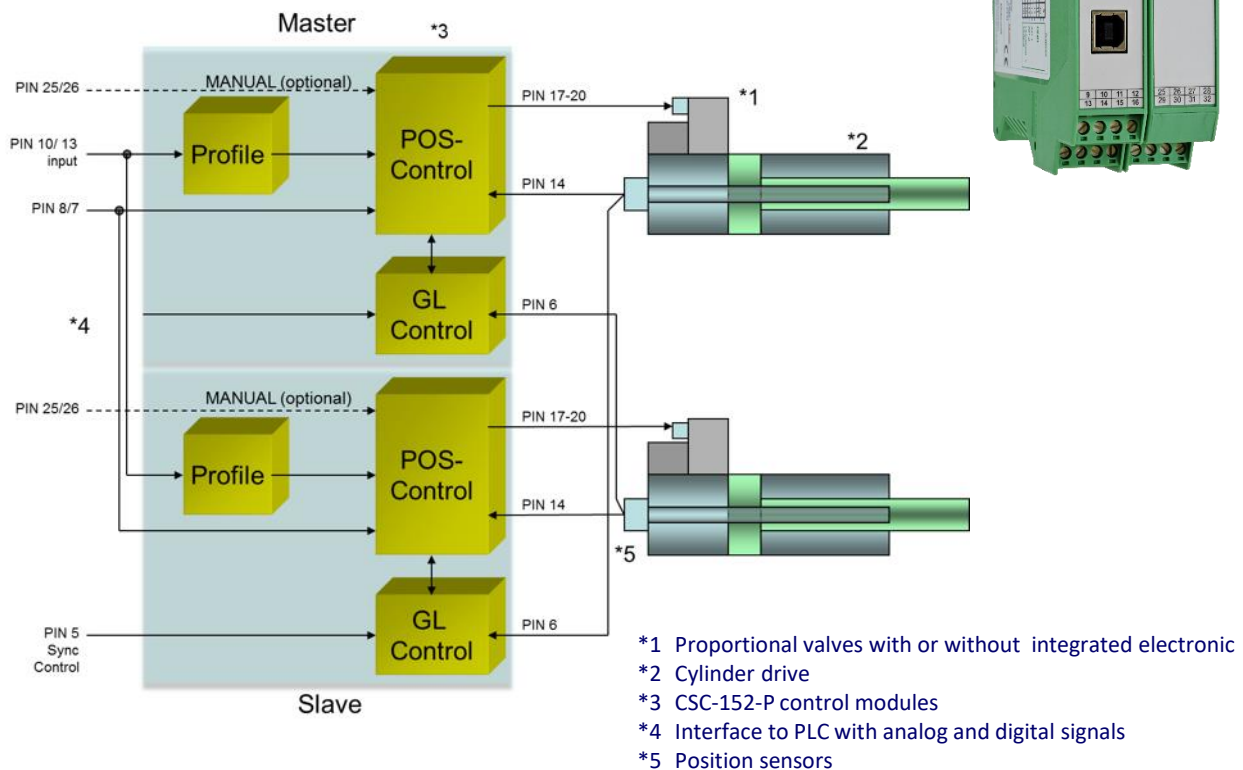

- ✓ Analog position and speed inputs
- ✓ Analog feedback sensor
- ✓ Simple and intuitive scaling of the sensor
- ✓ Internal profile definition by acceleration, velocity and deceleration
- ✓ Principle of stroke-dependent deceleration for fast and robust positioning
- ✓ NC profile generator for constant speed
- ✓ Superimposed synchronization controller

Versions	Model code
Standard module	CSC-152-U
Standard module with power output stage	CSC-152-P

CSC-156-U-SSIC + PCK-306-C

Synchronization system with pressure limitation control, SSI and Profibus interface for 2 to 4 axes

With a system consisting of one PCK-306 and up to four CSC-156 modules, typical synchronization applications like e.g. press and calander controls are possible. Additionally to the positioning and synchronization controller, a pressure limitation controller (differential pressure or force control) is implemented. The function can be adapted to the respective requirements via the various control bits.



Positioning: Similar to our standard positioning controller, the system can be used as point-to-point-control (stroke depended deceleration) or in NC-mode (speed controlled). By means of a few parameters, the controller gets optimized, the profile generation is set via the fieldbus (position and speed).

Synchronization control: Additionally, a superimposed synchronization control can be activated. As control structure, a PI or rather PT1 structure is used. According to the requirements, the master slave concept as well as the average determination (control of all axes to an internal calculated demand position depending on single positions and the command position) are available.

Pressure/force control: With one/two pressure sensors the force can be measured and limited. When the system switches over from synchronization control to pressure/force limitation control, the pressure limitation controller takes the priority.

CSC-156-U-SSIC + PCK-306-C

Synchronization system with pressure limitation control,
SSI and Profibus interface for 2 to 4 axes

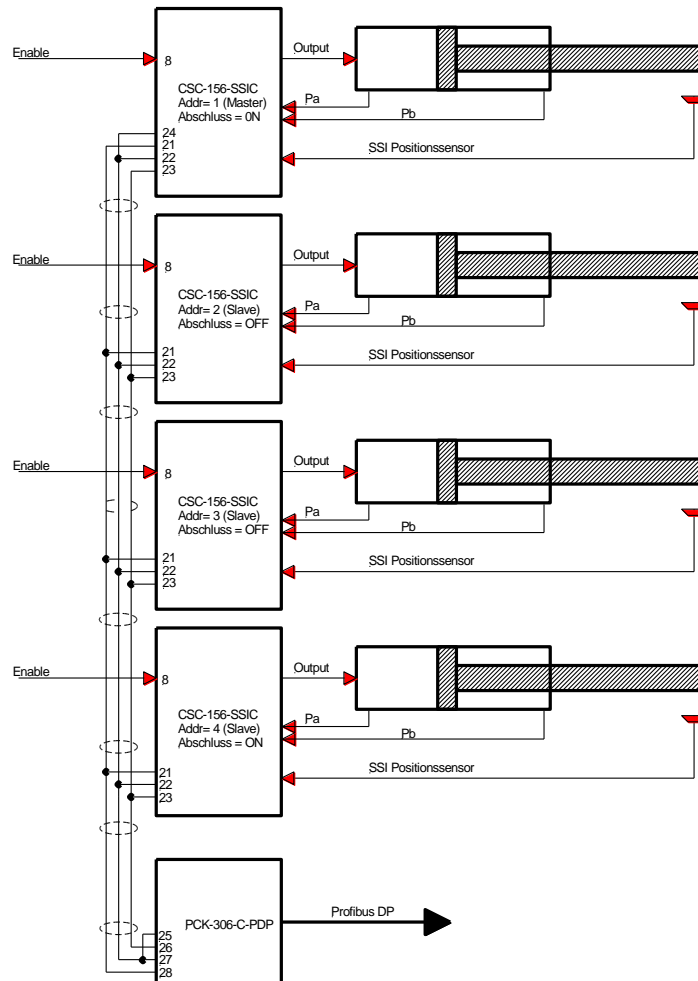

- ✓ Command values, actual values, control and status byte via fieldbus
- ✓ Sensor resolution up to 1µm
- ✓ Speed controlled positioning (alternatively: principle of stroke dependent deceleration)
- ✓ Synchronization control function as PI or PT1 controller
- ✓ Optional pressure limitation function
- ✓ SSI Interface or analog position sensors
- ✓ Internal profile definition by setting acceleration and deceleration
- ✓ Optimal use with zero lapped control valves

Versions	Model code
Standard module	CSC-156-U-SSIC
Coupling module with Profibus interface	PCK-306-C-PDP

UHC-126-U-PFN-S2

Axis control module with universal positioning, pressure limitation control and Fieldbus interface, special version for distributed synchronization control

This electronic module was developed for controlling the position and/or pressure of a hydraulic axis via the integrated fieldbus interface. The hydraulic axis can be driven as positioning control with digital stroke measurement (SSI interface) or by analog sensors.

Additionally, an integrated pressure limitation control function for one or two pressure sensors (differential pressure) is implemented. Command signals and actual values are transmitted by a fieldbus communication interface. Feedback are status information and actual values.

Proportional valves with integrated electronics (typically control valves) can be driven by the analogue output. Internal failure and the system statuses are monitored. The ready output is available as a fieldbus information and parallel as a hardware output.

The parameterization is performed via a USB interface in combination with our PC program WPC-300. Alternatively, defined parameters can be modified via the fieldbus interface.

Typical applications: general positioning drives, fast transport drives, handling systems, speed-controlled axes and presses with positioning and pressure control.

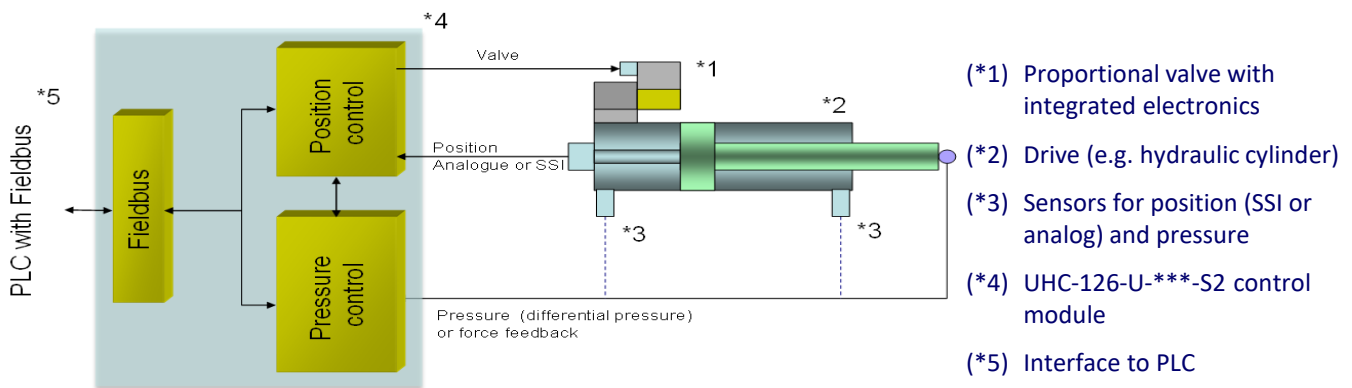

- ✓ Fieldbus for command values, sensor values, control word and status word
- ✓ SSI- or analog feedback sensors (0... 10 V or 4... 20 mA)
- ✓ Resolution up to 1 μm (SSI - interface)
- ✓ Speed resolution 0,005 mm/s
- ✓ Positioning mode: NC with internal profile generator
- ✓ Synchronised start of several axes, synchronisation monitoring, delayed start to realise a distributed synchronisation control system
- ✓ Alternatively continuous command signal transition
- ✓ Differential pressure limitation control or direct pressure control
- ✓ Expanded closed loop control functions: PT1 filter, Drift compensation for optimal zero point adjustment, accurate positioning by compensation of force depended positioning deviations, feed forward to reduce the following error and acceleration feedback by measuring the differential pressure (used to improve the dynamic behavior in case of low dynamics drives)
- ✓ Usable with overlapped proportional valves and with zero lapped control valves
- ✓ Fault diagnosis and extended function checking
- ✓ Simplified parameterization with WPC-300 software

Versions	Model code
Standard module	UHC-126-U-PFN-S2

WEST Elektronik GmbH

Pump Control Modules

The modules in this section offer solutions specifically for the requirements of variable displacement pumps.

Possibilities for closed loop displacement control, open loop displacement control with additional pressure control (p / Q) or the combination of closed loop displacement control and pressure control are available. The power control resp. load limit control are available as an option.

- PQP-171 Universal pump control module for displacement control
- PQP-176 Universal pump control module with integrated power stage
- PQP-176 PFN Universal pump control module with integrated power stage and Profinet-Interface

PQP-171-P

Universal pump control module

This module is used as a universal closed loop control module, e.g. for swivel angle control. It has an integrated power amplifier for proportional valves. Several parameters offer optimal adaption to the respective valve. The controller runs with a loop time of 1 ms and the amplifier with 0.125 ms for the current control.

The command value and the feedback value are read in by scalable analog signals (range 0... 10 V or 4... 20 mA). Ramp function and PID controller can be used universally. The output current is closed loop controlled and therefore independent of the supply voltage and a varying solenoid resistance. The output stage is monitored for cable breakage and switches off in case of detected errors.

Programmable are the standard PID control parameters and a threshold value for the integrator limitation and activation as well as various parameters for the valve adaptation. The operation is simple and problem-oriented, whereby a very short training period can be ensured.

Typical applications: swivel angle control.

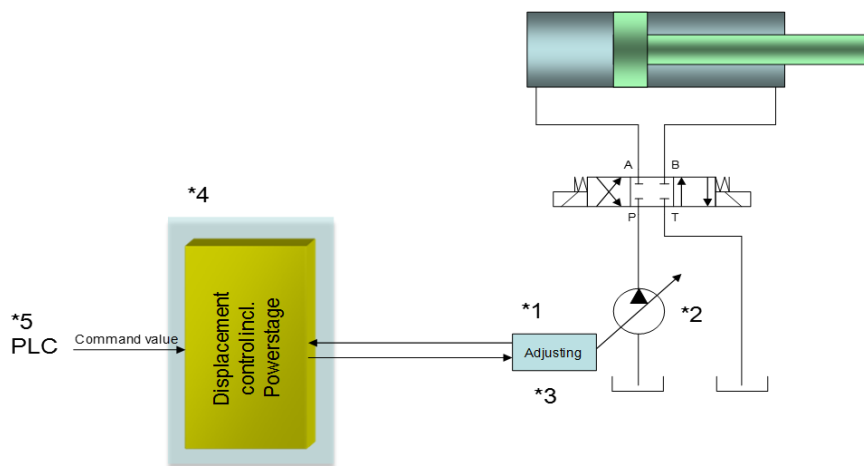

- *1 Swivel angle adjustment
- *2 Servo pump
- *3 Swivel angle sensor
- *4 Pump controller PQP-171-P
- *5 Interface to PLC

- ✓ Universal pump control module for proportional valves
- ✓ Digital reproducible adjustments
- ✓ Free scaling of the analog input signals
- ✓ Universal PID controller
- ✓ Control of proportional valves with one or two solenoids
- ✓ Free parameterization of the valve adaption
- ✓ Output current up to 2.6 A
- ✓ Adaptable to all standard proportional valves

Versions

Standard module

Model code

PQP-171-P

PQP-176-P

Universal pump control module with integrated power stage

This device represents a pump controller for the displacement, pressure and power/torque control of servo pumps.

The module can control directional valves for swivel angle adjustment of the pump with one or two solenoids. For controlling valves with integrated electronic the power stage can be deactivated.

Control structure is a cascade regulation which makes it universal for using with many different pumps of several producers. Negative swiveling for active pressure reducing (mooring mode) can also be parameterized.

Miscellaneous parameters allow an optimal adaption to the relating application.

The command values and the feedback values are read in via scalable analogue signals in the range of 0... 10 V or 4... 20 mA.

The output current is closed loop controlled and therefore independent from the supply voltage and a varying solenoid resistance. The output stage is monitored for broken cable and switches off in case of detected error. Because of the easy and job-oriented handling a very short training period is guaranteed.

Typical applications: General pressure control with pressure valves (direct or via a servo pump).

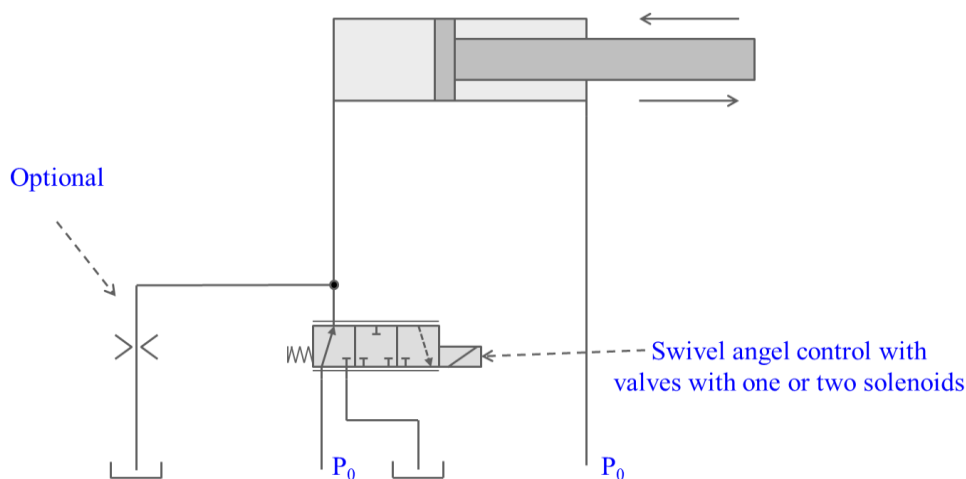

- ✓ Displacement, pressure and power limitation control
- ✓ Digital reproducible adjustments
- ✓ Free scaling of the analogue input signals
- ✓ Compact housing
- ✓ Optimized control function
- ✓ Application oriented parameterizing
- ✓ Two parameter sets for the pressure controller
- ✓ Swivel angle limitation function
- ✓ Integrated power stage
- ✓ Alternative analogue output for controlling valves with OBE

Versions

Standard module with power stage

Model code

PQP-176-P

PQP-176-P-PFN

Universal pump control module with integrated power stage and Profinet interface

This device represents a pump controller for the displacement, pressure and power/torque control of servo pumps. The demands are given via ProfinetIO. Actual values and status information are read back via this connection.

The module can control a directional valve for swivel angle adjustment of the pump with one or two solenoids. For controlling valves with integrated electronic the power stage can be deactivated.

Control structure is a cascade regulation which makes it universal for using with many different pumps of several producers. Negative swiveling for active pressure reducing (mooring mode) can also be parameterized.

Miscellaneous parameters allow an optimal adaption to the relating application.

The feedback values can be read in as voltage or current signals in the range of 0... 10 V respectively 4... 20 mA. The inputs are scalable for adapting individual signal ranges. When using current signals the inputs are cable break monitored. For the swivel angle sensor also voltage signals can be monitored.

Typical applications: Swivel angle control, pressure control and power limitation control.

The output current is closed loop controlled and therefore independent from the supply voltage and a varying solenoid resistance. The output stage includes a broken wire detection and switches off in case of a detected error.

Because of the easy and job-oriented handling a very short training period is guaranteed.

The fieldbus interface provides a continuous monitoring of actual values and operating states.

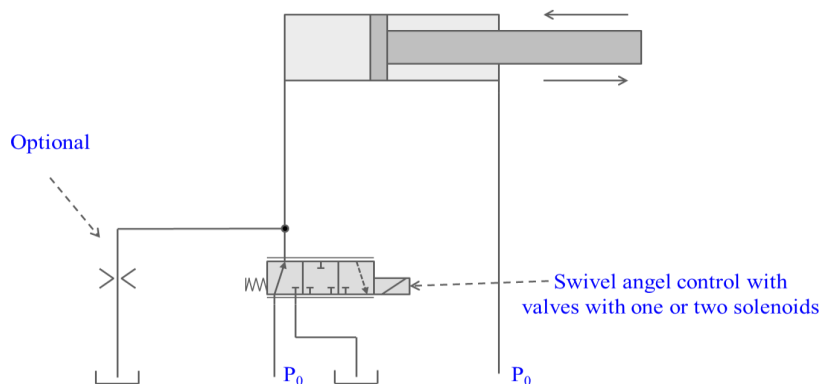

- ✓ Displacement, pressure and power limitation control
- ✓ Digital reproducible adjustments
- ✓ Two input channels for the actual pressure value, switchover via bus command possible
- ✓ Compact housing
- ✓ Optimized control function
- ✓ Application oriented parameterizing
- ✓ Two parameter sets for the pressure controller
- ✓ Controlling and monitoring via fieldbus
- ✓ Integrated power stage
- ✓ Alternative analogue output for controlling valves with OBE

Versions

Standard module with power stage and Profinet interface

Model code

PQP-176-P-PFN

WEST Elektronik GmbH

Power amplifiers

For proportional valves. Easy use with all proportional valve types. Highlight is an attractive price in conjunction with simplest handling. Thereby the digital PAM-199 is the most universal device with the largest range of functionality.

MOT-114 Power amplifier with motor potentiometer function

PAM-140 Universal mobile power amplifier

PAM-190 Power plug for proportional valves

PAM-193 Power amplifier for proportional valves

PAM-195 S3, power amplifier with hydraulic power limitation

PAM-195 PVG, ratio metric input compatible with Danfoss

PAM-198 Power amplifier with feedback positioning control

PAM-199 Power amplifier for all typical proportional valves

PAM-199 Fieldbus versions (PFN, ETC and PDP)

SV-200 Power amplifier for servo valves

MOT-114-P

Power amplifier with motor potentiometer function

This module is used for the control of proportional valves with one or two solenoids. Various parameters allow an optimized adaptation to the corresponding valve. The integrated power amplifier with a control/cycle time of 0.125 ms is inexpensive and a space-saving solution.

This amplifier is controlled via switching inputs.

The switching inputs are assigned freely programmable demand values, which are approached via the ramp function when the corresponding switching signal is activated. Optionally, the last stored value can be used as command value after switching on and activating.

The output current is closed loop controlled and therefore independent of supply voltage and solenoid resistance. The current output is observed with regard to cable breakdown and over current (short circuit) and switches off in case of detected errors.

Typical applications: adjustable pressure via UP/DOWN buttons.

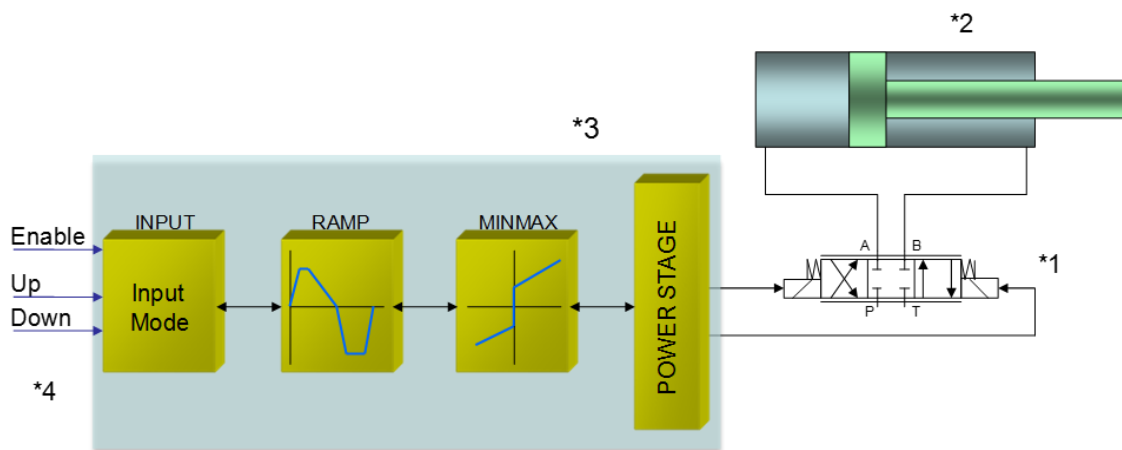

- *1 Proportional valve
- *2 Hydraulic drive
- *3 Power amplifier MOT-114-P
- *4 Interface to PLC

- ✓ Motor potentiometer function (saving of the last adjusted value and restarting with this value)
- ✓ Digital reproducible adjustments
- ✓ Characteristic linearization via 10 XY-points per direction
- ✓ Controlling valves with one or two solenoids
- ✓ Free parameterization of the valve adaption
- ✓ Nominal output current up to 2.6 A
- ✓ Adaptable to all standard proportional valves

Versions	Model code
Standard module	MOT-114-P

PAM-140-P / PAM-190-P

Universal mobile power amplifier

This power amplifier is used to control proportional valves with one solenoid. The compact solution is implemented in an inexpensive IP-65 housing. Optionally, the amplifier can be mounted directly with DIN plug (PAM-190) or with separate housing (PAM-140).

A typical input signal of 0... 10 V (optional 4... 20 mA) can be used.

The output current is closed loop controlled and therefore independent of the supply voltage and a varying solenoid resistance.

The parameterization can be done via the PC interface by the ULA-310 adapter or internally via the UP and DOWN buttons.

Via the free parameterization of the power amplifier, all typical proportional valves of the different manufacturers can be adapted.

Typical applications: controlling of the solenoid of proportional throttle or pressure valves as well as general inductive loads.



- ✓ Power amplifier for proportional valves in a DIN EN 175 301-803 A plug housing or as a printed circuit board in a robust housing (IP65) for free wiring
- ✓ Digital reproducible adjustments
- ✓ Free scaling of the input signal
- ✓ Also usable as soft-switch amplifier (soft switch-on and switch-off)
- ✓ M12 connector
- ✓ Adaptable to all standard proportional valves
- ✓ Reference output to supply potentiometers
- ✓ Current range: 1 A and 2.5 A
- ✓ Adjustments via LIN/USB interface, simplified parameterizing with WPC-300 software
- ✓ Parameter settings via integrated buttons and a selector switch (reduced functionally against the USB / LIN-bus)

Versions	Model code
Standard module with 0... 10 V input	PAM-140-P-A
Standard power plug with 0... 10 mA input	PAM-190-P-A
Standard power plug with 4... 20 mA input	PAM-190-P-I

PAM-190-P-IO

Amplifier plug for proportional valves with IO-Link interface

This amplifier plug is used to control proportional valves with one solenoid. The compact and inexpensive solution will be mounted directly on the solenoid.

The device is intended for control and parameterization via I / O - Link and has a Port Class B. The standard M12-plug enables the connection to IO-Link Master.

The output current is closed loop controlled and therefore independent from the supply voltage and a varying solenoid resistance.

By the free parameterization of the amplifier plug all typical proportional valves of the different manufactures can be optimal adapted.

Typical applications: Controlling of the solenoid of proportional throttle or pressure valves and for current control in general inductive loads.



- ✓ Power amplifier for proportional valves mounted in a DIN EN 175 301-803-A plug housing
- ✓ I/O-Link Port Class B, with internal galvanic isolation of the auxiliary power source
- ✓ Complies with specification V1.1, data rate COM3 = 230,4 kBaud
- ✓ Digitally reproducible adjustments
- ✓ Also usable as Soft-Switch-amplifier (soft switch-on and switch-off)
- ✓ M12 connector
- ✓ Parameterization via I/O - Link
- ✓ Free adjustment of ramps, MIN and MAX, DITHER (frequency, amplitude) and
- ✓ PWM frequency
- ✓ Output current up to 2.5 A, parameterizable
- ✓ Adaptable to all standard proportional valves

Versions	Model code
Standard power plug with I/O-Link interface	PAM-190-P-IO

PAM-193

Power amplifier for proportional valves

This module is used for the control of proportional valves with one or two solenoids. Various adjustable parameters enable an optimized adaptation to the respective valve. This power amplifier is inexpensive and a space-saving solution.

The amplifier can be controlled by different voltage or current input signals. The output current is closed loop controlled and therefore independent of the supply voltage and the solenoid resistance.

Several potentiometers and DIL switches allow the adaption to valves of various types of valves.

Typical applications: control of proportional valves in different applications.

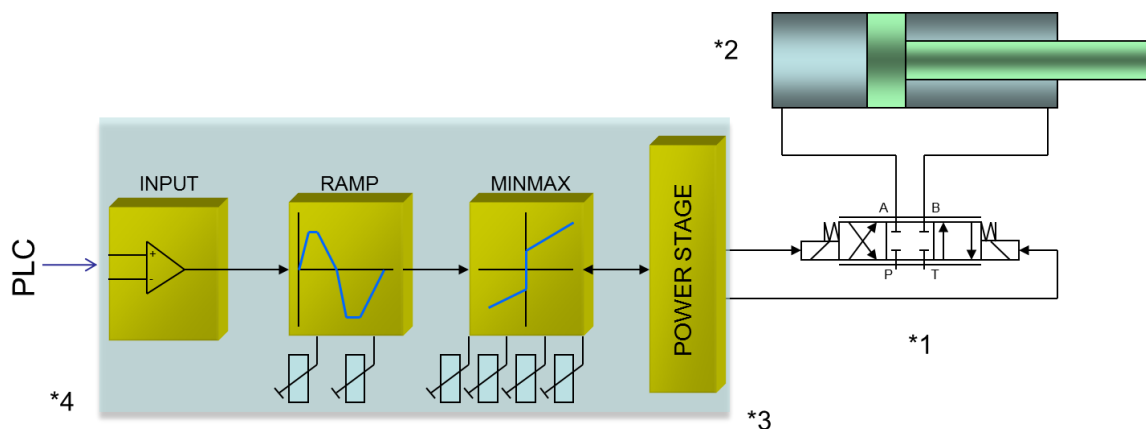

- *1 Proportional valve
- *2 Hydraulic cylinder
- *3 Power amplifier PAM-193
- *4 Interface to PLC with analog and digital signals

- ✓ Power amplifier for proportional valves
- ✓ Various command signals via DIL switch
- ✓ Free valve adaption via potentiometer
- ✓ Universal use in different applications
- ✓ Current range (per DIL switch): up to 2.6 A

Versions	Model code
Standard module (max. output current: 1,3 A and 2,6 A)	PAM-193-P
Standard module (max. output current: 0,65 A and 1,3 A)	PAM-193-L
Special version MIN directly active	PAM-193-P-S3

PAM-195-P-S3

Power amplifier for directional valves with integrated power limitation function

This module is used for the control of a directional valve with two solenoids or a pressure or throttle valve with one solenoid. Various adjustable parameters allow an optimized adaptation to the respective valve. The integrated power amplifier with a short cycle time of 0.125 ms for the current loop is an inexpensive and space-saving solution.

Additionally to the amplifier function, a power limitation functionality via pressure measuring was implemented. A simple unipolar output (0... 10 V / 4... 20 mA) or a bipolar signal from +/- 10V can control this amplifier. The polarity can be switched by a digital input, too.

The output current is closed loop controlled and therefore independent of the power supply and the solenoid resistance. The output stage is monitored for cable breakdown, short-circuit proof and it disables the power stage in case of an error.

RAMP times, MIN and MAX, DITHER (frequency and amplitude) and the PWM frequency are programmable. In addition, the valve characteristics can be linearized via 10 XY-points.

Typical applications: control of directional and throttle valves. All typical proportional valves of the different manufacturers (BOSCH, REXROTH, PARKER, EATON ...) can be used.

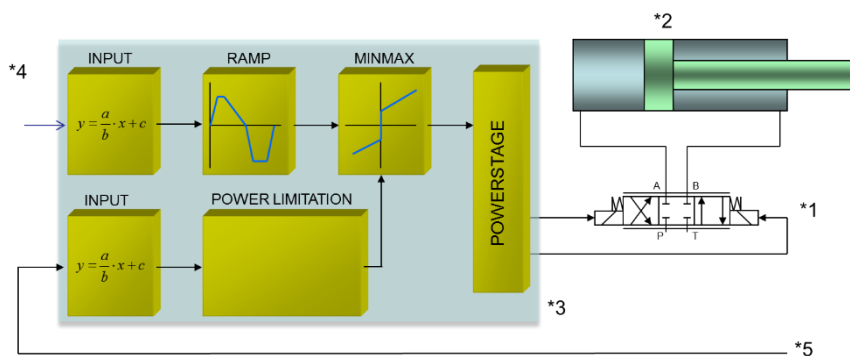

- *1 Proportional valve
- *2 Hydraulic cylinder
- *3 Power amplifier PAM-195-P-S3
- *4 Interface to PLC with analog and digital signals
- *5 Power input, from pressure sensor or pump

- ✓ Control of directional or throttle valves
- ✓ Digital reproducible adjustments
- ✓ Free scaling of the analog inputs
- ✓ **Extended function:** power limitation for energy saving
- ✓ Unipolar control with direction switch
- ✓ Bipolar control via differential input
- ✓ Characteristics linearization via 10 XY-points per direction
- ✓ Free parameterization of the valve adaption
- ✓ Nominal output current up to 2.6 A

Versions	Model code
Standard module	PAM-195-P-S3

PAM-195-P-PVG

Power amplifier for directional valves with ratio metric control

This module is used for the control of a directional valve with two solenoids. Various adjustable parameters allow an optimized adaptation to the respective valve. The integrated power amplifier with a short cycle time of 0.125 ms for the current loop is an inexpensive and space-saving solution.

Command value setting is realized via a ratio metric input. Means the command signal is given as a percentage of the supply voltage. For this purpose, the current supply voltage is measured via a separate input. Via the command signal input, a value is set with 25 % (for 100 % opening of the B side) up to 75 % (for 100 % opening of the A side) of the supply voltage. 50 % representing the zero position of the valve.

The output current is closed loop controlled and therefore independent of the power supply and the solenoid resistance. The output stage is monitored for cable breakdown, short-circuit proof and it disables the power stage in case of an error.

RAMP times, MIN and MAX, DITHER (frequency and amplitude) and the PWM frequency are programmable. In addition, the valve characteristics can be linearized via 10 XY-points.

Typical applications: control of directional valves with ratio metric joystick input (Danfoss compatible control).

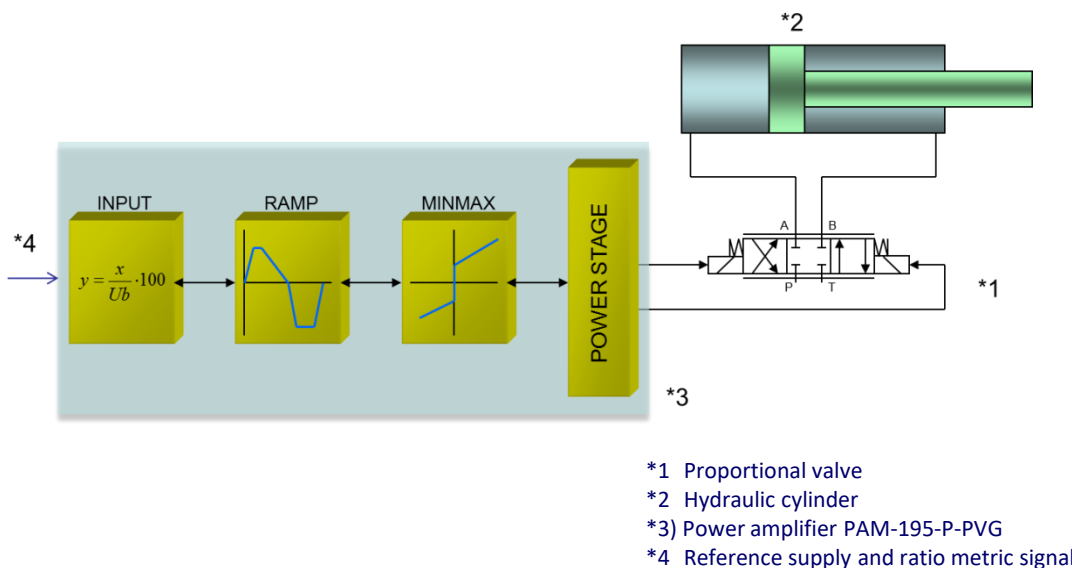

- ✓ Control of directional valves
- ✓ Digital reproducible adjustments
- ✓ Ratio metric command value input
- ✓ Separate reference input for the ratio metric command input
- ✓ Characteristics linearization via 10 XY-points per direction
- ✓ Free parameterization of the valve adaption
- ✓ Nominal output current up to 2.6 A

Versions

Standard module

Model code

PAM-195-P-PVG

PAM-198-P

Power amplifier for directional valves with feedback position control

This module is used for controlling directional valves with spool position feedback. Various adjustable parameters allow an optimized adaptation to the respective valve. The closed loop controller works with a cycle time of one millisecond and the current controller with 125 microseconds. The inputs for demand and feedback are free scalable for voltage and current signals. Because the output is closed loop current controlled it is independent from the supply voltage and solenoid resistance.



MODE OF OPERATION:

This power amplifier with spool position feedback is controlled by an analog command signal. The ENABLE signal activates the power stage and application functionality and the READY output reports an error free operation. In case of an error the power stage gets deactivated and the error is reported by a deactivated READY output and a flashing READY LED. The output current is closed loop controlled which leads to a high accuracy and a good dynamic. Superior controller is the spool position controller. It has a feed forward function for fast reactions when the command value changes and a switching integrator with parameterizable deadband in order to avoid limit cycling at the operation point. The output can be adapted to valves with one or two solenoids. In open loop control mode the power stage can be controlled by the feed forward function which leads the command value directly to the output. In closed loop control mode the control deviation and parameterizing of the controller define the output signal.

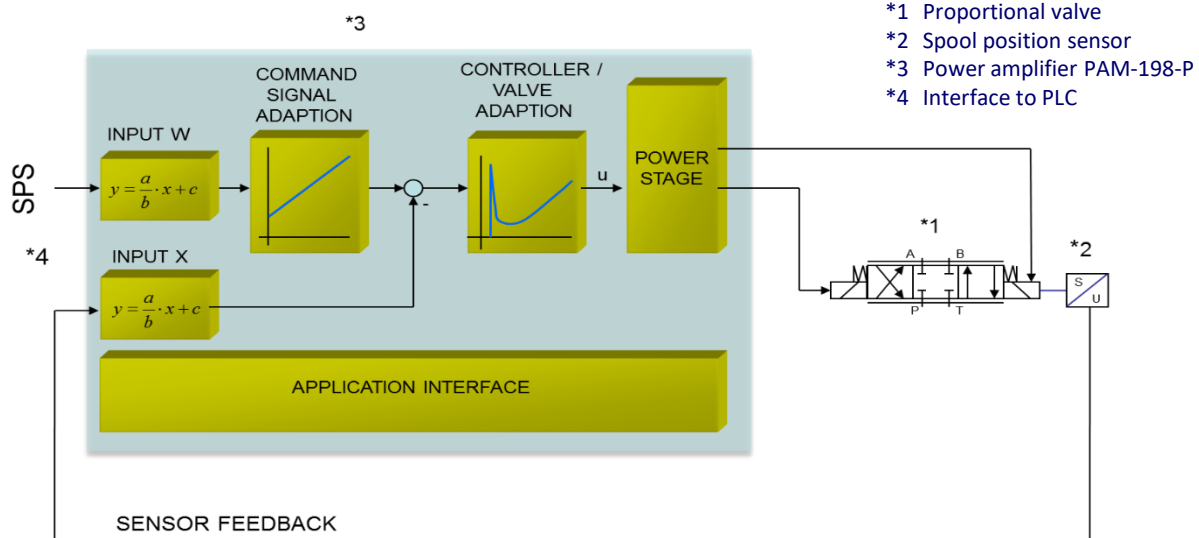

- ✓ Control of directional valves with spool position control
- ✓ Free scaling of the analog inputs
- ✓ PID controller with feed forward function
- ✓ Free parameterization of the valve adaption
- ✓ Characteristics linearization of the output signal
- ✓ Nominal solenoid current parameterizable up to 2.6 A
- ✓ (Cable break) Monitoring of the current input and output signals
- ✓ Digital reproducible adjustments
- ✓ Application oriented parameterization

Versions	Model code
Standard module	PAM-198

PAM-199-P

Power amplifier for all typical proportional valves

This module is used for the control of one directional valve with two solenoids or one/two independent pressure or throttle valves with one solenoid each. Various adjustable parameters allow for an optimized adaptation to the respective valve. The integrated power amplifier with a short cycle time of 0.125 ms for the current loop is an inexpensive and space-saving solution.



FUNCTION MODES:

195: The amplifier can be used to control one directional valve. The current is controlled by a +/- 10 V (or 4... 20 mA with cable breakdown monitoring) input signal.

196: This one can be used to control one/two throttle or pressure valves. The output current is controlled by 0... 10 V (or 4... 20 mA with cable breakdown monitoring) input signal.

197: The amplifier can be used to control proportional valves with one or two solenoids by three digital input signals to select up to eight pre-programmed command and ramp values.

The output current is closed loop controlled and therefore independent of the power supply and the solenoid resistance. The output stage is monitored for cable breakdown, short-circuit proof and disables the power stage in case of an error.

RAMP times, MIN and MAX, DITHER (frequency and amplitude) and the PWM frequency are programmable. In addition, the valve characteristics can be linearized via 10 XY-points. For example: Using pressure valves, a linear behavior between input signal and pressure can be reached.

Typical applications: control of directional, throttle and pressure valves, which need a flexible adaptation of the solenoid control. All typical proportional valves of the different manufacturers (BOSCH, REXROTH, PARKER, EATON ...) can be controlled.

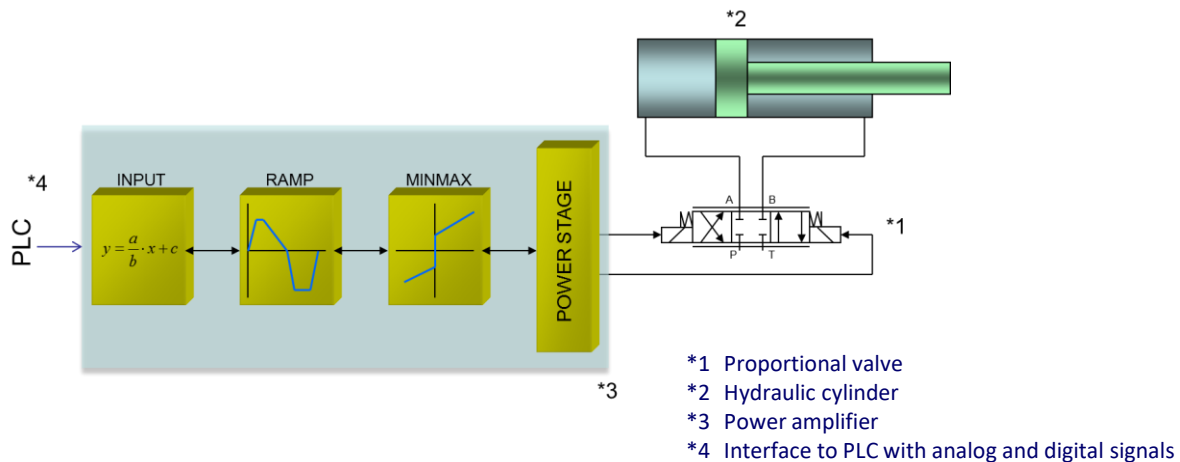

- ✓ GL-certification
- ✓ Control of directional valves or two pressure or throttle valves
- ✓ Controlled by analog or digital inputs
- ✓ Digital reproducible adjustments
- ✓ Free scaling of the analog inputs
- ✓ Monitoring of the input signal (e.g. joysticks)
- ✓ Characteristics linearization via 10 XY-points per direction
- ✓ Free parameterization of the valve adaption
- ✓ Nominal output current up to 2.6 A

Versions	Model code
Standard module	PAM-199-P

PAM-199-P-ETC / PAM-199-P-PFN / PAM-199-P-PDP

Power amplifier for all typical proportional valves

This module is used for controlling one directional valve with two solenoids or up to two throttle valves with one solenoid. The functionality corresponds to the standard PAM-199-P, with the difference that the analog interfaces are omitted and the module is controlled directly via a fieldbus like EtherCAT or Profinet (in preparation).

The advantage of fieldbus-capable power amplifiers is the more simple integration into the machine control, the better diagnosis possibilities, the cabling, the possibility of automatic parameterization in case of a device exchange and the significantly lower total costs (analog and digital IOs can be omitted on the control side).

Typical applications: control of directional and pressure valves, which need a flexible adaptation. All typical proportional valves of the different manufacturers (BOSCH, REXROTH, PARKER, EATON ...) can be controlled.

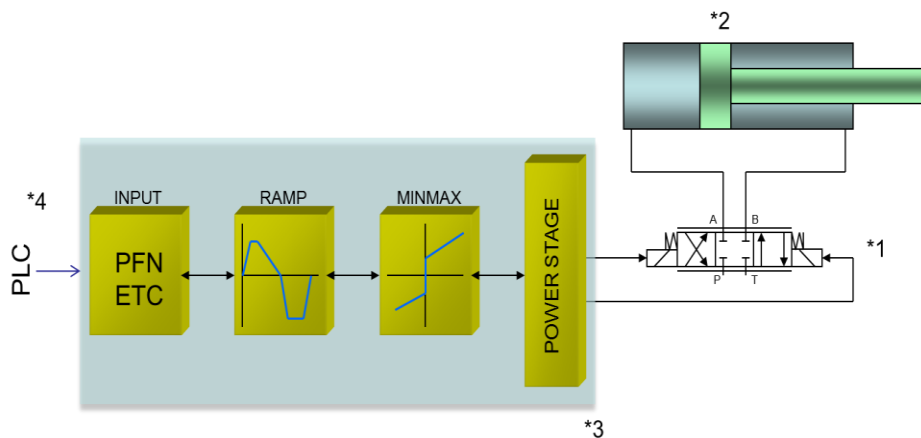

- *1 Proportional valve
- *2 Hydraulic cylinder
- *3 Power amplifier
- *4 Interface to PLC with analog or digital signals



- ✓ Integrated fieldbus interface (EtherCAT, Profinet)
- ✓ Control of directional valves or two pressure or throttle valves
- ✓ Digital reproducible adjustments
- ✓ Optimal interaction with valves from various manufacturers
- ✓ Nominal output current : 0,5... 2,6 (3,0) A

Versions	Model code
Standard module with EtherCAT	PAM-199-P-ETC
Standard module with Profinet	PAM-199-P-PFN
Standard module with Profibus	PAM-199-P-PDP

SV-200 / SV-300

Power amplifier for servo valves

This module was developed for the control of hydraulic servo valves.

The amplifier is controlled by a ± 10 V signal. The output current can be adapted via DIL switches between 10 mA and 200 mA.

This device provides a positive reference voltage as well as a negative one (+10 V and -10 V).

Dither and offset settings are realized with potentiometers.

Typical applications: dynamic control of servo valves.

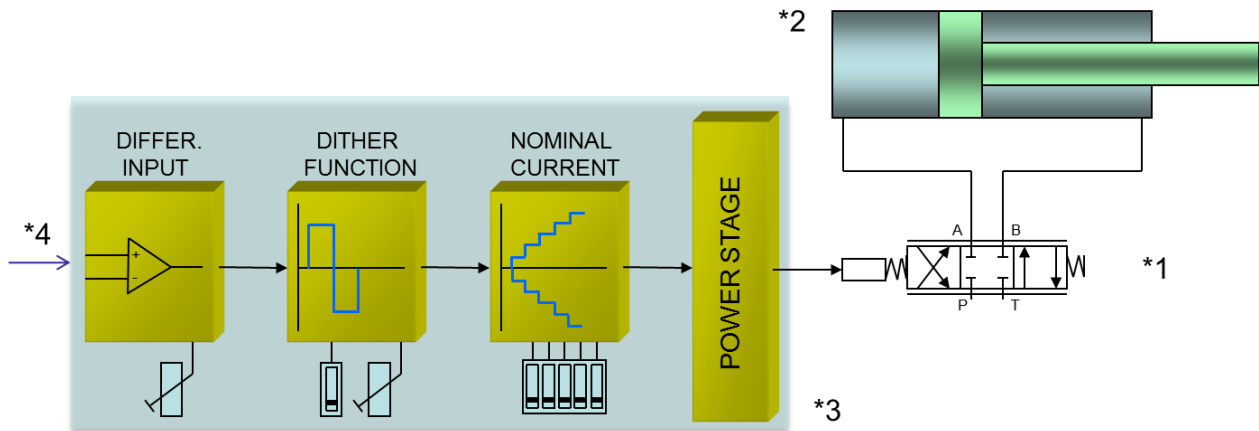

- *1 Servo valve
- *2 Hydraulic cylinder
- *3 Power amplifier SV-200
- *4 Interface to PLC

- ✓ power amplifier for servo valves
- ✓ compact format
- ✓ low cost snap in housing
- ✓ positive and negative reference voltage provided
- ✓ maximum output current can be set in 10 mA steps
- ✓ offset adaptation
- ✓ stepless adjustment of the dither amplitude

Versions	Model code
Standard module up to 200 mA	SV-200
Standard module up to 300 mA	SV-300

We have the vision of making our customers' work easier by bringing electro-hydraulic drive technology forward with intelligent products.

Our strengths

- Control and regulation modules with optimized application-related functions
- Can be used directly and without external commissioning costs
- Excellent price-performance ratio
- Robust and easy to use
- Over 20 years of experience with the development of electronics for hydraulic applications
- Highest product and service quality
- Universal applicability for the various valve manufacturers
- Short delivery time
- Free technical support



The Team

The *W.E.St. Elektronik* team consists of long-term employees with a high level of expertise and passion for their respective field. Our relaxed working atmosphere enables structured, creative and constructive cooperation between the individual departments. The result are products that reliably meet your requirements.



Technology

- Excellent expert knowledge regarding the use in hydraulic systems
- Implementation of an expert system for the analysis of the system behavior and for the automatic parameter setting
- New innovative control technology, patent pending
- Safe products thanks to high MTTFd values
- Based on our standards, with the help of W.E.St. Software library you can also realize own developments
- Own special solutions on proven hardware are possible. Our tested hardware including bootloader is then available for serial use.



Development and quality

W.E.St. Elektronik offers the entire process, from the first idea to optimized serial production. The consistently high quality of our products is guaranteed by:

- Top qualified employees and specialists
- Short distances to suppliers in the immediate vicinity
- High quality products "**Made in Germany**"
- **ISO-9001** certificate since 2008
- A powerful development process
- An optimized test procedure
- **100% quality control** in our house

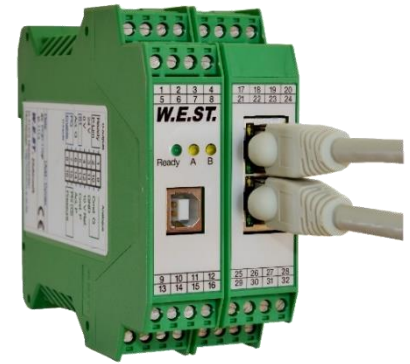
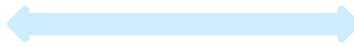
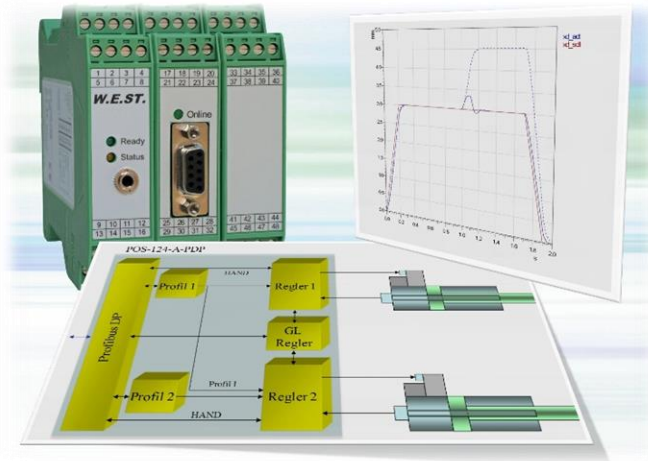

Smart connection between control and hydraulics

In order to be able to offer robust modules suitable for everyday use, it is necessary to maintain a well-planned basic concept from the first module. This is the only way that technically mature modules can assert themselves on the market for more than 20 years.

- Uniform user interface and uniform operating concept for all modules.
- Powerful processors with a 15-year delivery guarantee from the manufacturer
- High compatibility with all previously delivered modules
- Shortest commissioning times by the customer
- Application-oriented description (application notes) for faster familiarization



Industrie **4.0** EtherCAT[®] PROFIBUS[®] IO-Link[®]
smart hydraulics enable smart machines

W.E.ST. *Hydraulics meets Electronics.*

WEST. Elektronik GmbH

Start-up and operation tool WPC-300

- *Simple and clearly arranged parameterization of the devices via PC / Notebook*
- *Evaluation of the process data in real time in monitor or oscilloscope view*
- *Display of error messages and status information*
- *Remote control of the devices via the program*
- *Intuitive operation without extensive training*

WPC-300 is an assistance to adjust and optimize our modules

The screenshot displays the WPC-300 software interface with several key components highlighted by callouts:

- Parameter table, sorted in groups. Help texts can be blended in and out.** This callout points to the left-hand pane containing a list of parameters such as 'SYSTEM', 'ID_CONFIG', 'START_UP', 'CONTROL', and 'Einspeisung'.
- Monitor for processdata / Alternatively oscilloscope view** This callout points to the central data display area showing real-time values for parameters like 'WA' (0,08 mm), 'W' (119,13 mm), 'V' (100,00 %), 'X' (174,88 mm), 'E' (-55,75 mm), 'C' (-22,30 %), 'U' (-22,30 %), 'IA' (851,00 mA), and 'IB' (867,00 mA).
- Status messages / Operation via remote control** This callout points to the bottom section of the interface, which includes 'Status Informationen' (READY, ACA-ACTIVE, ACA-ERROR) and 'Fernsteuerung einschalten' (Digital and Analog Inputs).
- Information about connection and device** This callout points to the bottom status bar showing 'Connected', 'COM7', 'FDX', '115200', and 'WPC-300-P-2030-USim'.

**W.E.St. Elektronik GmbH**

Gewerbering 31
41372 Niederkrüchten
Germany

Phone: 0049 (0) 2163 577355-0
Fax: 0049 (0) 2163 577355-11

E-Mail Addresses:

General: contact@w-e-st.de
Sales: order@w-e-st.de
Technical support: technics@w-e-st.de

Homepage: www.w-e-st.de

Our partner in China:

Shanghai Dwyer Mechanical and Electrical Equipment Co., Ltd
Room A1603, Building 1, No.5666 Shenzhuan Road
Songjiang District
201619 Shanghai
People's Republic of China

Phone: 0086 21 67828020
Fax: 0086 21 67828027

info@dwyer.com
www.dwyer.com

Managing director: Thomas Helpenstein, Johan Andreas Lázár
Fotos: Ulrich Walter, fotolia, Photomotics

Technical changes reserved
© 2020 – W.E.St. Elektronik GmbH