



THYRO-S

THYRISTOR-SCHALTER Thyro-S 1S...H 1 Thyro-S 1S...H RL1

THYRISTOR-SWITCH Thyro-S 1S...H 1 Thyro-S 1S...H RL1

AUGUST 2015

8000029341 DE/EN - V7





THYRO-S

THYRISTOR-SCHALTER Thyro-S 1S...H 1 Thyro-S 1S...H RL1

THYRISTOR-SWITCH Thyro-S 1S...H 1 Thyro-S 1S...H RL1

AUGUST 2015 8000029341 DE/EN - V7



CONTACT

TECHNICAL QUERIES

Do you have any technical queries regarding the subjects dealt with in these operating instructions?

If so, please get in touch with our team for power controllers:

Tel. +49(0)2902 763-520 or 763-290

Fax +49(0)2902 763-1201

COMMERCIAL QUERIES

Do you have any commercial queries on power controllers?

If so, please get in touch with our team for power controllers.

Tel. +49 (0)2902 763-558 or (02902) 763-591

powercontroller@aei.com

SERVICE

Our team is at your service on the following hotline:

Advanced Energy Industries GmbH

Emil-Siepmann-Straße 32

D-59581 Warstein

Tel. +49 (0)2902 763-558

www.advanced-energy.com

COPYRIGHT

No part of these operating instructions may be transmitted, reproduced and/or copied by any electronic or mechanical means without the express prior written permission of Advanced Energy.

© Copyright Advanced Energy Industries GmbH 2014.

All rights reserved.

FURTHER INFORMATION ON COPYRIGHT

Thyro-S is a registered trademark of Advanced Energy Industries GmbH.

Windows and Windows NT are registered trademarks of the Microsoft Corporation.

All other company and product names are (registered) trademarks of the respective owners.

SAFETY INSTRUCTIONS

The following safety and operating instructions must be carefully read before assembly, installation and commissioning.

OBLIGATION TO GIVE INSTRUCTIONS

The following safety and operating instructions must be carefully read before initial assembly, installation and commissioning of Thyro-S by those persons working with or on Thyro-S.

These operating instructions are part of the Thyristor switch Thyro-S. The operator of this device is obliged to provide, without restriction, these operating instructions to all persons transporting, commissioning, maintaining or performing other work on this device.

In accordance with the Product Liability Act, the manufacturer of a product has an obligation to provide explanations and warnings as follows:

- the use of the product other than for the intended use,
- the residual product risk as well as
- operating errors and their consequences.

The information given below must be understood in this respect. It is to warn the product user and protect him and his systems.

PROPER USE

- The Thyristor switch is a component which may only be used for control and regulation of electrical energy.
- The Thyristor switch may at most be operated using the maximum admissible connected load according to information on the type plate.
- The Thyristor switch may only be operated in connection with a suitable and series connected power supply disconnecting device.
- As a component, the Thyristor switch is unable to operate alone and must be projected for its intended use to minimize residual risks.
- The Thyristor switch may only be operated in the sense of its intended use, otherwise hazards to persons (e.g. electric shocks, burns) and systems (e.g. overload) may arise.

RESIDUAL HAZARDS OF THE PRODUCT

- Even in case of proper use, should a fault occur, it is possible that control of currents, voltages and power is no longer performed in the load circuit by the Thyristor switch.

In case of destruction of the power components (e.g break-down or high resistance), the following situations are possible: power interruption, half-wave operation, continuous power flow. If such a situation occurs, then load voltages and currents are produced from the physical dimensions of the overall power circuit. It must be ensured by system design that no uncontrolled large currents, voltages or power occur.

MALOPERATION AND ITS RESULTS

- With maloperation it is possible that power, voltage or flow levels which are higher than planned reach the Thyristor switch or load. On principle, this can lead to the Thyristor switch or load being damaged.

TRANSPORT

- Thyristor switches are only to be transported in their original packaging (protection against damage e.g. due to jolting, knocking, soiling).

INSTALLATION

- If the Thyristor switch is brought into the operation room from a cold environment, moisture can occur. Prior to it being commissioned, the Thyristor switch must be absolutely dry. Therefore, wait for a minimum of two hours before commissioning.

CONNECTION

- Prior to connection, it must be ensured that the voltage information on the type plate corresponds with the mains voltage.
- The electrical connection is carried out at the designated points with the required cross section and the appropriate screw cross sections.

OPERATION

- The Thyristor switch may only be connected to the mains voltage if it has been ensured that any hazard to people and system, especially in

the load section, has been eliminated.

- Protect the device from dust and moisture.
- Do not block vents.

MAINTENANCE, SERVICE, MALFUNCTIONS

CAUTION



For maintenance and repair work the Thyristor switch must be disconnected from all external voltage sources and protected against restarting. Make sure to wait minimum 1 minute after switch-off (discharge time of the attenuation capacitors). The voltage-free state is to be determined by means of suitable measuring instruments. This work is only to be carried out by a skilled electrician. The electrical regulations which are locally valid are to be adhered to.



CAUTION

The Thyristor switch contains dangerous voltages. Repairs may only be carried out by qualified and trained maintenance personnel.



CAUTION

Danger of electric shock. Even after disconnection from the mains voltage, capacitors may still contain a dangerously high power level.



CAUTION

Danger of electric shocks. Even when the Thyristor switch is not triggered, the load circuit is not disconnected from the mains.



ATTENTION

Different components in the power section are screwed into place using exact torques. For safety reasons, power component repairs must be performed by Advanced Energy Industries GmbH.

CONTENTS

Contact	2
Safety instructions	3
Safety regulations	9
Remarks on the present operating instructions and Thyro-S	12
1. Introduction	13
1.1 General	13
1.2 Specific characteristics Thyro-S	13
1.2.1 Additional for 1S...H RL1	14
1.3 Type designation	14
2. Functions	15
2.1 Operating modes	15
2.1.1 Digital set point value inputs	15
2.1.2 Switching behaviour	15
2.2 Indications	16
2.3 Monitoring	16
2.3.1 Monitoring of the mains voltage	16
2.3.2 Equipment temperature monitoring	16
2.3.3 Ventilator monitoring	16
2.4 Additional indications using type S...H RL1	17
2.4.1 Error indication relay K1	17
2.5 Additional monitoring using type S...H RL1	17
2.5.1 Thyristor short-circuit monitoring	17
2.5.2 Load monitoring (undercurrent monitoring)	18
2.5.3 Load monitoring (overcurrent monitoring)	18
3. Operation	20
3.1 Configuration switch S1	20
3.2 Thyro-Tool Family	21
3.3 Diagnosis / status indications	21
4. External connections	23
4.1 Power supply for Thyro-S	23
4.2 Power supply for the control electronics	23
4.3 Additional control voltage input	23
4.4 Digital set point input	24
4.5 Block diagram 1S...H 1	25
4.6 Connections and terminal strips 1S...H1	26
4.7 Block connection diagram 1S ... H RL1	27
4.8 Connections and terminal strips	28

5. Interfaces	30
5.1 Bus module at the systems interface	30
5.2 PC-Interface RS232 at the system interface	30
5.2.1 Thyro-Tool Family	31
6. Mains load optimization	32
7. Connecting diagrams	32
8. Special remarks	37
8.1 Installation	37
8.2 Commissioning	37
8.3 Service	37
8.4 Checklist	38
9. Type overview	39
9.1 Typ 1S...H 1	39
9.2 Typ 1S...H RL1	39
10. Technical data	40
11. Dimensional drawings	42
Dimensional drawing Thyro-S 1S (16H, 30H)	42
Dimensional drawing Thyro-S 1S (45H, 60H)	42
Dimensional drawing Thyro-S 1S (100H)	43
Dimensional drawing Thyro-S 1S (130H, 170H)	43
Dimensional drawing Thyro-S 1S (280H)	44
12. Accessories and options	45
13. Approvals and conformities	46

LIST OF ILLUSTRATIONS AND TABLES

Fig. 1	Block diagram 1S...H1	25
Fig. 2	Terminal plan 1S...H1	26
Fig. 3	Operation 1S...H 1	26
Fig. 4	Block diagram 1S...H RL1	27
Fig. 5	Terminal plan 1S...H RL1	28
Fig. 6	Operation Thyro 1S...H RL 1	29
Fig. 7	User surface Thyro-Tool Family	31
Fig. 8	Connecting diagram Thyro-S 1S...H 1	33
Fig. 9	Connecting diagram 2x Thyro-S 1S...H 1	34
Fig. 10	Connecting diagram Thyro-S 1S...H RL 1	35
Fig. 11	Connecting diagram 2x Thyro-S 1S...H RL 1	36
Tab. 1	Load monitoring	19
Tab. 2	LED signals Thyro-S	22

SAFETY REGULATIONS

IMPORTANT INSTRUCTIONS AND EXPLANATIONS

The skilled personnel assembling and disassembling the devices, commissioning them and maintaining them must know and observe these safety regulations.



CAUTION

This instruction indicates work and operating procedures to be observed exactly to exclude hazards to persons.



ATTENTION

This instruction refers to work and operating procedures to be observed exactly to avoid damage or destruction of Thyro-S or parts thereof.



REMARK

This is where remarks on technical requirements and additional information is given which the user must observe.

ACCIDENT PREVENTION RULES

It is imperative that the accident prevention rules of the country of application and the generally applicable safety regulations are observed.



CAUTION

Before commencing any work on Thyro-S, the following safety regulations must be observed:

- switch voltage-free
- secure against switching on
- determine voltage-free state
- ground and short-circuit device
- cover or block neighbouring parts under voltage.

QUALIFIED PERSONNEL

Thyro-S may only be transported, installed, connected, commissioned, maintained and operated by specialists in command of the respective applicable safety and installation regulations. All work must be monitored by the responsible specialist personnel.

INTENDED USE



CAUTION

The Thyristor switch may only be employed in the sense of its purpose of use (see the section of the chapter Safety instructions under the same name), otherwise hazards to persons (e.g. electric shocks, burns) and systems (e.g. overload) may occur.

Any unauthorized reconstruction and modification of Thyro-S, use of spare and exchange parts not approved by Advanced Energy as well as any other use of Thyro-S is not permitted.

The person responsible for the system must ensure that

- safety and operating instructions are available and observed,
- operating conditions and specifications are observed,
- protective installations are used,
- maintenance personnel are immediately notified or Thyro-S is immediately put out of commission if abnormal voltages or noises, higher temperatures, vibrations or similar occur, to determine the causes.

These operating instructions contain all information required by specialists for the use of Thyro-S. Additional information and notes for unqualified persons and for the use of Thyro-S outside of industrial installations are not contained in these operating instructions.

The warranty given by the manufacturer is only valid if these operating instructions are observed and adhered to.

WARRANTY

No liability is assumed for employing applications not provided for by the manufacturer. The responsibility for the necessary measures to avoid hazards to persons and property is borne by the operator or the user. In case of complaints, please notify us immediately stating:

Type name	Production number
Complaint	Ambient conditions
Operating mode	Duration of use

GUIDELINES

The CE mark on the device confirms adherence to the general EC guidelines for 2006/95 EEC – low voltage and for 2004/108 EEC electromagnetic compatibility if the instructions on installation and commissioning described in the operating instructions are observed.

REMARKS ON THE PRESENT OPERATING INSTRUCTIONS AND THYRO-S

VALIDITY

These operating instructions refer to the latest technical specification of Thyro-S at the time of publication. The contents are not subject matter of the contract, but serve only as information. Modification of information contained in these operating instructions, especially technical data, operation, dimensions and weights, remain reserved at any time. Advanced Energy reserves the right to content modifications and technical changes within the present operating instructions without obligation to notification.

Advanced Energy is not obliged to update these operating instructions constantly.

LOSS OF WARRANTY

Our supplies and services are subject to the general terms and conditions of delivery of the electrical industry as well as our general sales conditions. Any complaints on goods delivered are to be submitted, together with the delivery note, within eight days of receipt.

All guarantees made by Advanced Energy and its dealers will be cancelled without prior notice if other than original Advanced Energy spare parts or spare parts purchased by Advanced Energy are used for maintenance and repair.

1. INTRODUCTION

Thyro-S meets the demands for simple assembly, speedy commissioning and safer operation.

For transport, assembly, installation, commissioning, operation and decommissioning, it is essential that the safety instructions included in these operating instructions are observed and made available to all persons handling this product.

In case of uncertainties or missing information, please contact your supplier.

1.1 GENERAL

Thyro-S is a Thyristor switch with the ability to communicate. It will also be referred to as Power Controller or simply controller. It can be used wherever voltages or currents need to be controlled in processing technology. With its good coupling ability to process and automation technology, high control precision and simple handling, Thyro-S is also future-orientated for new applications. The Thyro-S is suitable for a direct supply of ohmic loads.

1.2 SPECIFIC CHARACTERISTICS THYRO-S

Thyro-S has a wide range of distinguishing features, for instance

- easy handling
- type range 230-500 Volts, 16-280 A, single phase, 2-phase and 3-phase structure is possible
- ohmic load
- operating modes 1:1, as well as 1:2, 1:3 and 1:5 (e.g. for commissioning)
- Digital control with 24 V signal (> 3 V) or via optional bus module
- series system interface
- electrical separation according to EN 50178 chapt. 3
- Connection for optional visualization and commissioning

Options:

- Bus connection via bus adapter
Coupling to different bus systems, e.g. Profibus, Modbus RTU, CANopen and DeviceNet, other bus systems on request.
- PC software Thyro-Tool Family, visual and operational software

1.2.1 EXTENSION USING 1S...H RL1

- With additional 24 V control voltage supply also applicable for mains voltages $> 0.43 \times U_{\text{nom}}$
- Load circuit monitoring
- Indication relay

1.3 TYPE KEY

The type name of the thyristor switches is based on the construction of the power unit:

Thyro-S 1S Thyristor switch with 1 phase power unit,
suited to 1 phase loads

Example

...400-	with 400 Volt type voltage
...280	with 280 Amp type current
H	with integrated semi-conductor fuse
F	with ventilator (only 280 Amp types)
R	with indication relay
L	with load monitoring
1	designation Thyro-S, series

The complete type range can be found in chapter 9, TYPE OVERVIEW.

2. FUNCTIONS

2.1 OPERATING MODES

FULL WAVE SWITCH

Depending on the digital set point signal the mains voltage is switched. In the operating mode 1:1 almost no harmonics are created in the mains frequency. Whole multiples of the mains periods are always switched.

For commissioning etc, a reduced supply can be switched with the S1 switch or via the optional bus module, the control system thereby either forces the switching of every 2. wave or an equal number of positive and negative half waves.

In all operation modes d.c. components are avoided:

OPERATING MODE	LOAD VOLTAGE
1:1	every mains full wave (nom. oper. mode, default setting)
1:2	every 2. mains full wave (DC-free)
1:3	every 3. mains full wave (DC-free)
1:5	every 5. mains full wave (DC-free)

2.1.1 DIGITAL SET POINT INPUTS

The Thyristor switch Thyro-S is equipped with two set point inputs which are electrically isolated from the mains for triggering signals:

- | | |
|----------------------------------|--|
| • Set point input 1 ¹ | logic input 0-24 V DC ($R_i > 3,3 \text{ k}\Omega$) IN: $U_{IN} > 3 \text{ V}$ |
| • Set point input 2 | via bus module |

2.1.2 SWITCHING BEHAVIOUR

The Thyro-S can switch single or continuous full waves in the mains voltage to the load. If a voltage of $>3 \text{ V}$ is fed into X22.1 the following mains period is switched.

If a full wave is to be switched to the load, the trigger signal ON must be switched on not later than 1 ms before the mains voltage crossover otherwise it remains inactive. No new full wave is triggered if the trigger

signal is interrupted up to 1.25 ms before the crossover of the full wave. With a pulse trigger the pulse duration must be min. 1 ms.

2.2 INDICATIONS

The LEDs on the front signal the following states:

- ON GREEN operating indication, power supply controller device

Blinking indications are described in table 2.

2.3 MONITORING

2.3.1 MONITORING OF THE MAINS VOLTAGE

The limiting values of the voltage are -57% for undervoltage monitoring and +10% for overvoltage monitoring. This produces the following absolute limiting values:

Type	Undervoltage	Overvoltage
230 V	99 V	253 V
400 V	172 V	440 V
500 V	215 V	550 V



NOTE

The devices may only be operated up to the undervoltage limit if the electronics are supplied by an ext. 24 V voltage. If the undervoltage limit is undercut the pulse lock is activated and relay K1 is released (default).

1) See also chapter 4.4 digital set point input

2.3.2 EQUIPMENT TEMPERATURE MONITORING

The control board is equipped with a temperature monitor. If a fault occurs, the red LED blinks and pulse inhibitor will be released, however, it can be deactivated.

Please consider that by deactivation, the risk of overheating and/or damage of the unit exist in case of error.

2.3.3 VENTILATOR MONITORING

The separately ventilated power controllers (F) are fitted with thermal monitoring. The temperature of the heat sink is measured. In case of a temperature overrange a fault indication (red LED) ensues.

2.4 ADDITIONAL INDICATIONS USING TYPE S...H RL1

The LEDs on the front indicate the following situations:

• Diagnosis	GREEN	additional error diagnosis
• LOAD FAULT	RED	error present

Flashing LED indications are described in table 2. Whether the semiconductor fuse is responding can be indicated by the error indication relay K1 (undercurrent detection).

2.4.1 ERROR INDICATION RELAY K1

The K1 relay has a changer and deenergizes if an error is detected in the system (chapter 3.2). The table shows the pin connections on the terminal strip concerned.

	ROOT	N/O CONTACT	N/C CONTACT
Error indication relay K1	X3.1	X3.2	X3.3

2.5 ADDITIONAL INDICATIONS USING TYPE S...H RL1

Thyro-S ... H RL1 indicates errors occurring in the controller or load circuit.

Indications are given via LED (LOAD FAULT) and via the K1 relay.

The device continues to run during errors as standard (can be configured using the Thyro-Tool Family).

2.5.1 THYRISTOR SHORT-CIRCUIT MONITORING

The devices of the Thyro-S...H RL1 series have built in thyristor short-circuit monitoring. If no set point signal is available at the device, the thyristor short-circuit monitoring checks the current flow to the load. If a current >10% of the controller current is measured, the indication „thyristor short-circuit“ is given. In the case of an error the relay deenergizes, the Test-LED as well as the Load Fault LED flash intermittently and Bit 14 appears in the status word.

The relay function can be configured with the Thyro-Tool Family software.

The indication is only given if the error has been detected 3x and the break time is >2 mains periods..

2.5.2 LOAD MONITORING (UNDERCURRENT MONITORING)

Thyro-S ... H RL1 is suitable for monitoring loads resulting from one or several resistances in parallel or parallel series connection.

Thyro-S detects an increase in the load resistance. The load monitoring operates as undercurrent monitoring on absolute values and is suitable for use in the nominal operating mode 1:1, and with limitations in the operating modes 1:2, 1:3 and 1:5.

The load monitoring is supplied with the default configuration OFF = left stop R205 (=0)

For all other configurations:

If the load current falls below the level set the error indication relay will respond with a delay (4-10 sec depending on operating mode). The result is indicated via an optionally connected bus system.

This can be set in accordance with the following table.

2.5.3 LOAD MONITORING (OVERCURRENT MONITORING)

Along with undercurrent monitoring 2.5.2 the device also has over-current monitoring. This can only be configured using Thyro-Tool Family.

NO. OF PARALLEL LOAD RESIS- TANCES E.G.	$I_{LOAD\ NOM}/$ $I_{TYPE/CONTROLLER}$	RESISTANCE INCREASE IN CASE OF FAULT	RECOM- MENDED SETTING FOR POTI R205	POTI REVOLU- TIONS CA.
NUMBER				
1	100%		50.0%	8.5
1	80%		40.0%	7
1	60%	Infinite	30.0%	6
1	40%		20.0%	4.5
1	20%		10.0%	2.5
2	100%		75.0%	12
2	80%		60.0%	9.5
2	60%	100,0%	45.0%	7.5
2	40%		30.0%	6
2	20%		15.0%	3.5
3	100%		83.3%	13
3	80%		66.7%	12.5
3	60%	50%	50.0%	9
3	40%		33.3%	6
4	100%		87.5%	13.5
4	80%		70.0%	12.5
4	60%	33,3%	52.5%	9
4	40%		35.0%	6
5	100%		90.0%	14
5	80%		72.0%	11.5
5	60%	25,0%	54.0%	9
5	40%		36.0%	6.5

TAB. 1 LOAD MONITORING

Deviating values are to be converted by percentage. The set monitoring value should always be "midpoint" between the value with load current and the value after interruption.

**NOTE**

Settings above 90% and below 10% are not practical. If low load currents are required, check whether a controller with a lower type current can be used.

3. OPERATION

3.1 CONFIGURATION SWITCH S1

A 4-pole DIP switch is situated at the front behind the hood. The individual switches are marked from 1-4 starting from the bottom and must be set before operation. They are only read in once when switched on (mains recovery). For safety reasons further operation is carried out with the hood closed.

S1-	1	2	Operating mode
	0	0	1:1 operation, nom. Oper. mode (default setting)
	1	0	1:2 operation
	0	1	1:3 operation
	1	1	1:5 operation

For operations where initially no nominal load is possible (e.g.drying) reduced power can be controlled by Thyro-S independently.

With 1:2 operation each 2. cycle is switched, with 1:3 and 1:5 operation half cycles are switched with alternating polarity so that while switched on the load is supplied with d.c.-free energy.

S1-	3	Function
	0	default
	1	Thyro-Tool Family mode

Using the Thyro-Tool Family mode, all parameters can be configured by software.

The following table is valid for dip-switch 4:

S1-	4	Function
	0	default (resistive load)
	1	resistive - inductive load (with phase angle of 1st half wave)

By switch S1-4, the Thyro-S can be adjusted to resistive – inductive loads. This can be realized by phase angle of 1st half wave. If the switch is closed, the value for phase angle of 1st half wave (short AN1) can be adjusted by Thyro-Tool Family. The default value is 60°.

3.2 THYRO-TOOL FAMILY

Thyro-S 1S is suitable for operation with the visual and operational software Thyro-Tool Family. No special setting is necessary here. Further information is contained in chapter 5.

3.3 DIAGNOSIS / STATUS INDICATION

Faults can occur in the load circuit and in the controller itself or from the mains.

Diagnosis of unexpected operating behaviour is performed by LEDs on the front panel of the control device.

TAB. 2 LED SIGNALS THYRO-S

LED'S			
SIGNAL	ON	TEST (H230)	LOAD FAULT H250
Device without voltage supply	Off	Off	Off
Voltage supply exists	On	-	-
Frequency fault	On	Flash slow	Off
Synchronization fault	On	Flash slow	Off
Temperature fault	On	Off	Flash slow
Load errors or fallen below undercurrent limit	On	Off	On [only with H RL1]
Faulty parameter / flash value invalid	On	Flash fast*	Flash fast*
Undervoltage	On	On	On
Thyristor short-circuit	On	Flash slow	Flash slow [only with S-H RL1]

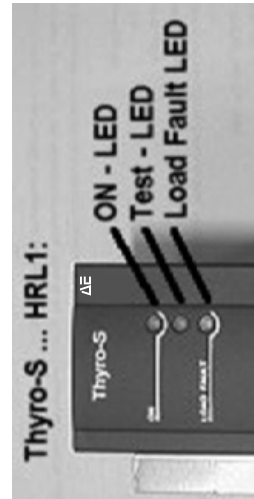

LED STATUS:

Off LED is continuously off

On LED is continuously on

Flash slow LED blinks slowly (1 Hz or 3.3 Hz)

Flash fast LED blinks fast or flickers (14.7 Hz)

- LED status optional

*LEDs blink synchronously

Further status messages are accessible through the system interface. (PC interface, order no. 2.000.000.845)

4. EXTERNAL CONNECTIONS

To connect the control signals use twisted or screened control lines. If the controller is being used in UL conditions then only 60°C or 75°C copper wires are to be used for the power connections in accordance with the instructions in the technical data.

4.1 POWER SUPPLY FOR THYRO-S

The connection of the power supply is to be made in accordance with the connection diagrams and TECHNICAL DATA.

4.2 POWER SUPPLY FOR CONTROL ELECTRONICS

The control electronics are usually supplied directly from the power connections. Connections U1 and X1.1 are needed for this.

This voltage (mains voltage) is used simultaneously for mains synchronisation. With device types H RL 1 a 24 V supply can be connected additionally (AC or DC). This is advantageous if, for example, you are using a bus system. With device types H 1 the mains voltage must be in the range of -57% to +10% from the type value; with device types H RL 1 in the range of -15% to +10%. If the mains voltage here is smaller than -15% then with these types the additional 24 V supply is needed. The permitted frequency range of the mains voltage is between 47Hz and 63 Hz. If the Thyro-S is operated between two phases, so if a phase is available at X1.1, then an additional fuse must be installed (see attached connection diagram on page 33-36). The connections X1.1 and X1.2 are bridged internally.

4.3 ADDITIONAL CONTROL VOLTAGE INPUT

The thyristor switch Thyro-S 1S H RL1 is equipped with an additional 24 V AC/DC power supply input. [X1: 1.2 1.5 mm², grid 3.5]. If needed, e.g. when operating with a bus, or voltages below the tolerance (e.g. with undervoltage of a 440 V mains with a 500 V Thyro-S) the control device can be supplied additionally with 24 V AC or DC. The 24 V voltage must be unearthed (SELV) and must not be connected to the control earth. However, several Thyro-S switches can be operated on a 24 V supply. The input is reverse polarity protected. The connection output for the control device is circa 2 W (5 VA) per actuator.

The 24 V connection lines are to be fused in accordance with the applicable regulations. A soldered in fuse protects the device in case of internal short-circuits.

4.4 DIGITAL SET POINT INPUT

The digital set point input X22.1 works with a logic signal. It can, for example, be gated by 24 V DC. If a voltage of more than 3 V is available at this input then the Thyro-S is switched on; below 3 V it is switched off. Between terminals X22.1 (input) and X22.2 (+15 V) a switch or relay contact, for example, can be operated. If a voltage is applied directly to X22.1 (+) then its reference point must be connected to X22.3 (earth). All control terminals are connectable with up to 1.5 mm² and have a 3.5 mm grid.

4.5 BLOCK DIAGRAM 1S...H 1

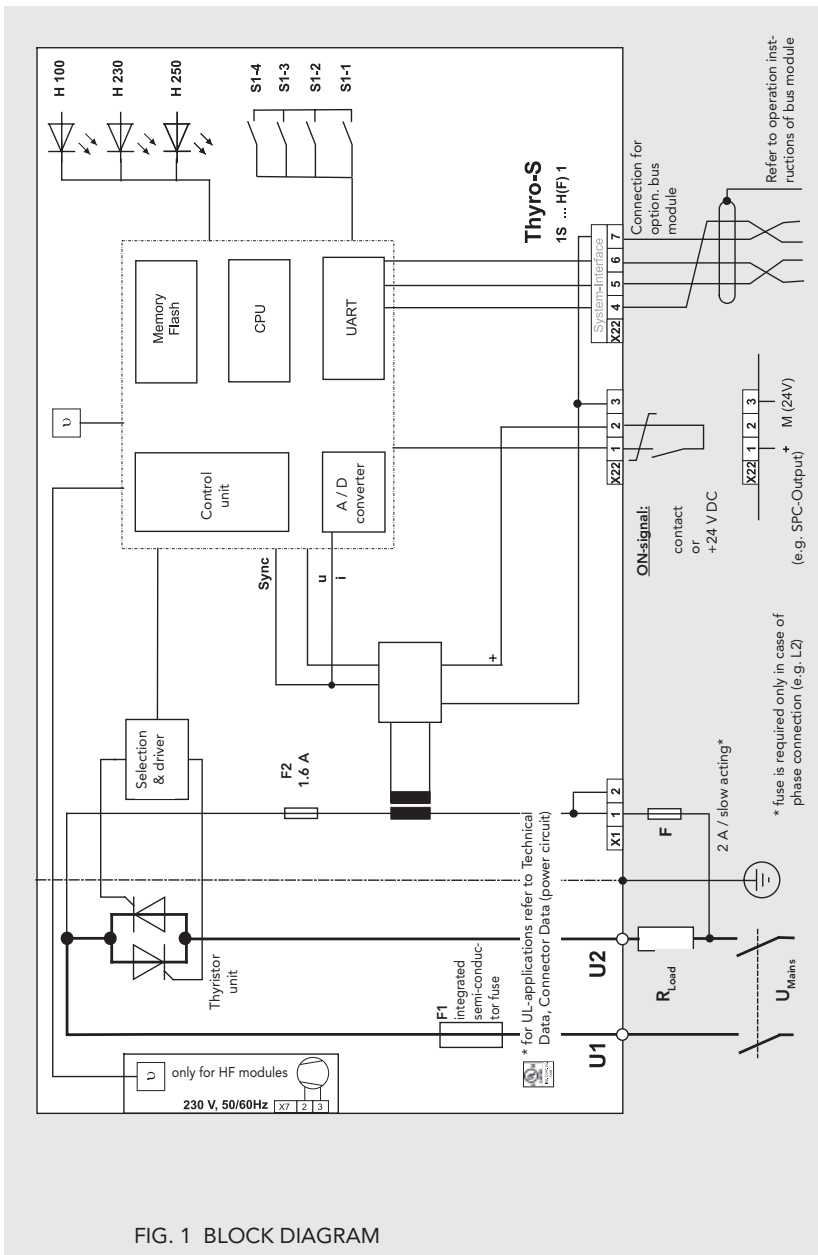
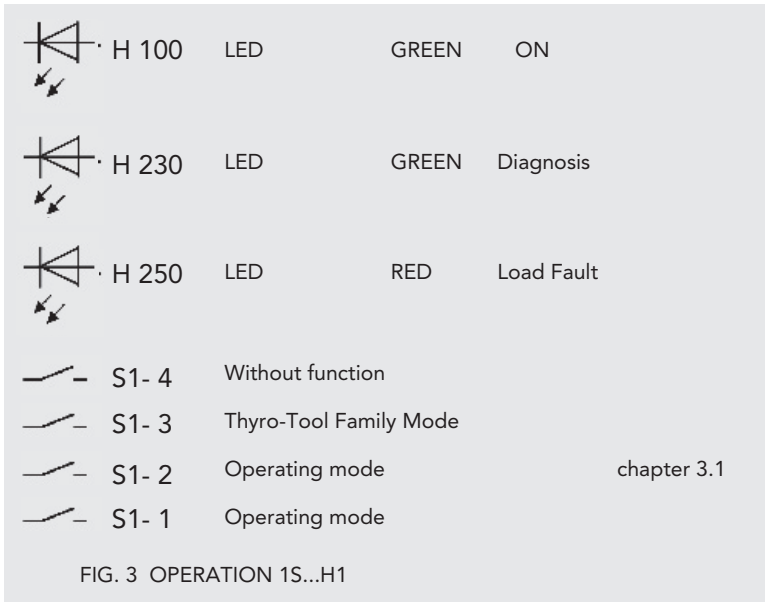
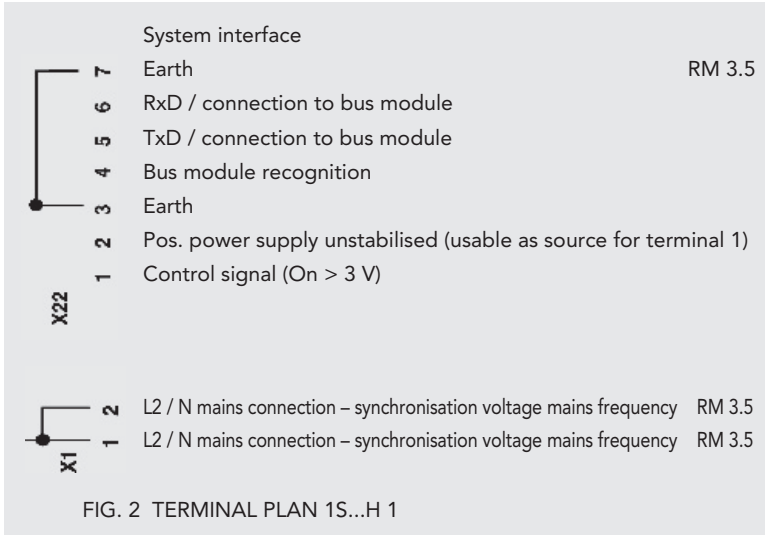

FIG. 1 BLOCK DIAGRAM

4.6 CONNECTIONS AND TERMINAL STRIPS 1S...H 1

This chapter describes all existing terminal strips and plug connections.



In the block diagram the functions of type H1 are shown.
The central control element is a μ -controller.

4.7 BLOCK DIAGRAM 1S ... H RL1

In the block diagram the functions of type H RL1 are shown. The central control element is a μ -controller.

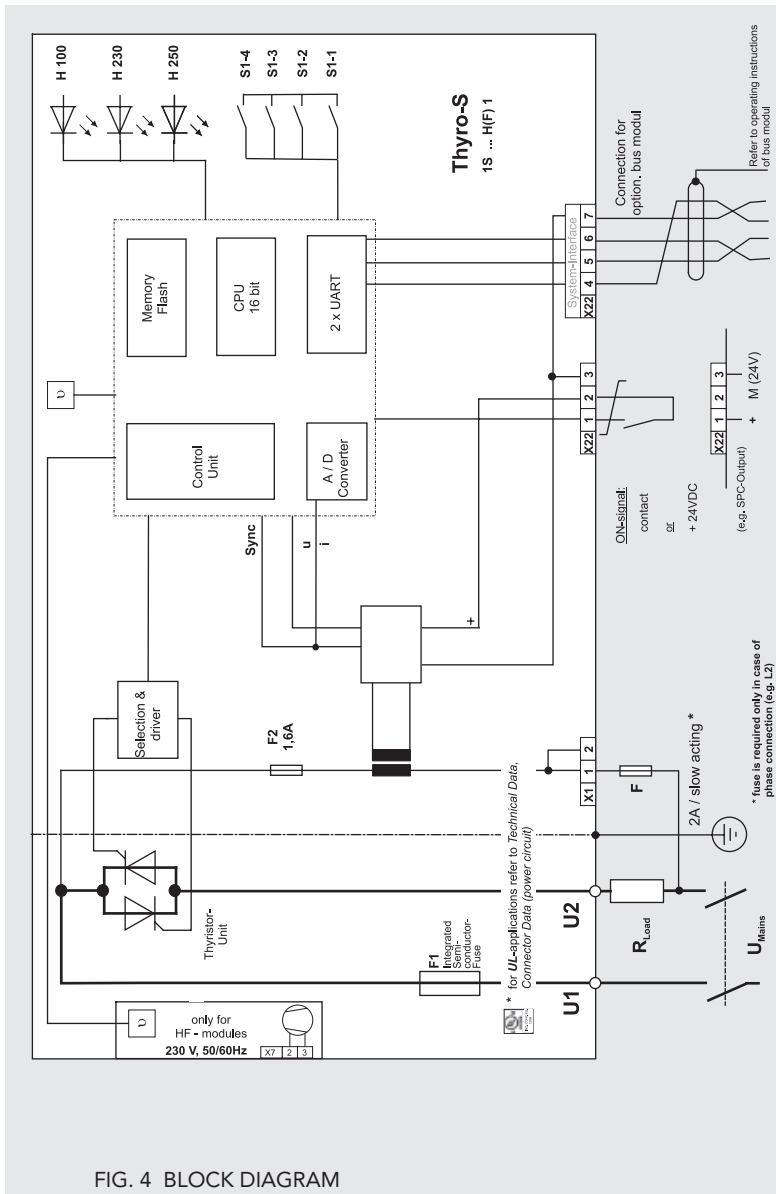

FIG. 4 BLOCK DIAGRAM

4.8 CONNECTIONS AND TERMINAL STRIPS

This chapter describes all existing terminal strips and plug connections.

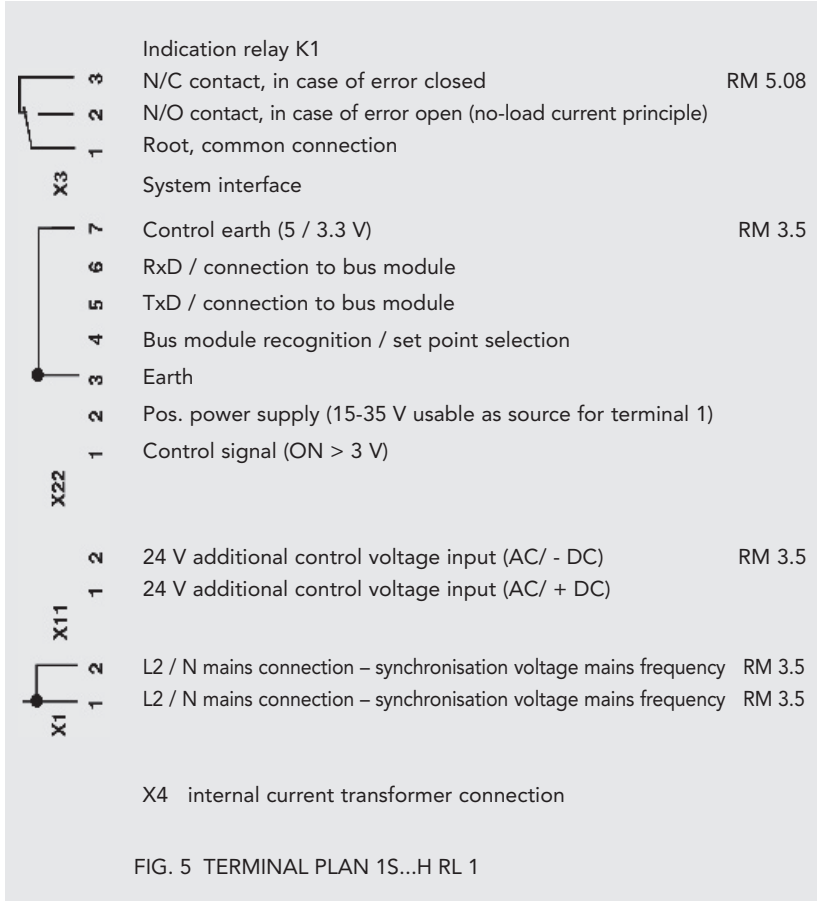

FIG. 5 TERMINAL PLAN 1S...H RL 1









	H 100	LED	GREEN	ON	
	H 230	LED	GREEN	Diagnosis	
	H 250	LED	RED	LOAD FAULT	
	S1-4	Without function			
	S1-3	Thyro-Tool Mode			chapter 3.1
	S1-2	Operating mode			chapter 3.1
	S1-1	Operating mode			
	R205	Load monitoring	LOAD FAULT		chapter 2.3

FIG. 6 OPERATION THYRO 1S...H RL1

5. INTERFACES

The Thyristor Switch of type range Thyro-S...1 are all equipped with a system interface at terminal strip X22. Either a bus module or a PC interface with a PC connection can be operated from this.

5.1 BUS MODULE AT THE SYSTEM INTERFACE

The optional bus module enables the Thyro-S range Power Controller to be connected to a field bus. The bus module is hereby connected to the Power Controller's system interface (terminal strip X22) with pre-fabricated cables on the bus module side. Up to eight Thyro-S (or also combined with Thyro-A) can be connected to the bus system with one bus module, e.g. Profibus-DP, Modbus RTU, CANopen or DeviceNet. The bus module connection configuration is identical for all available bus modules. Further information can be obtained from the operating instructions of the respective bus module.



REMARK

Further useful functions for the application are possible via field bus by the access of set point value, actual values, parameters as well as fault diagnosis.

5.2 PC-INTERFACE RS232 AT THE SYSTEM INTERFACE

The Power Controller is connected to a PC via the serial interface (COM1, COM2 ...) with the PC-INTERFACE RS232. In addition, an RS232-DATALINE, Order No. 6000016474 is needed (not crossed, the connection 2, 3, 4, 5 and 7 are used).

The PC-INTERFACE RS232 must be connected to the terminal strip X22 according to the instructions included.

5.2.1 THYRO-TOOL FAMILY

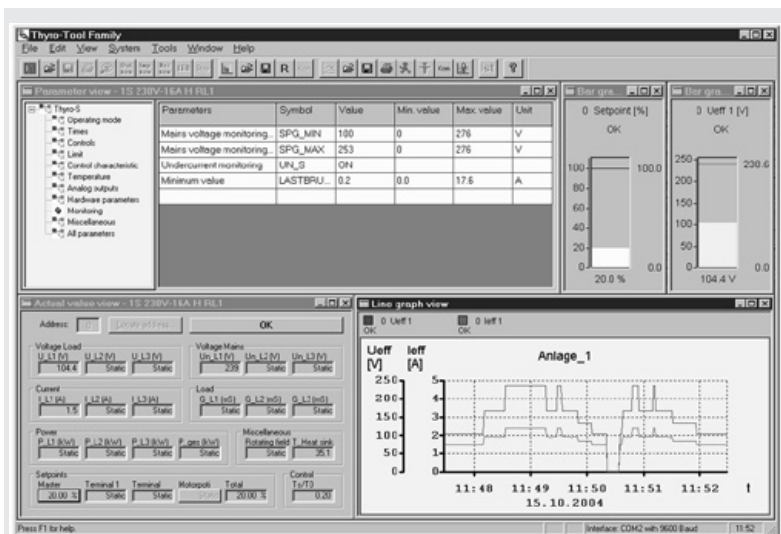

FIG. 7 USER SURFACE THYRO-TOOL FAMILY

Thyristor Switch of the Thyro-S range can be operated and set effortlessly with the aid of the PC software Thyro-Tool Family.

Necessary for working with Thyro-Tool Family is that the connection between PC and Power Controller is present (see 5.2). This makes visual readings, parameter viewing and fault diagnosis possible. If Thyro-S is not operated in Thyro-Tool mode, certain parameters can be changed. In Thyro-Tool mode changes to almost all parameters are possible.

To change over the set point a switch can be connected to the PC-INTERFACE RS232 and X1.3. If these terminals are connected, the digital set point of Thyro-Tool Family is active. With open terminals the analogue set point at X2.4 is used.

6. MAINS LOAD OPTIMIZATION

Thyro-S is not suitable for mains load optimization in multiple controller applications.

If mains load optimization is necessary, Thyristor controllers of type Thyro-A, Thyro-AX or Thyro-P must be used.

7. CONNECTING DIAGRAMS

Thyro-S can be employed in single phase switch and in three phase switches which can be transposed to single phase switches, e.g. star connections with MP conductor or N conductor and in open delta connection.

It is possible to apply 2 identical Thyro-S as a three phase saver circuit (with delta load or star without N), if the triggering signal for both controllers is set up at the same time (see fig. 11).

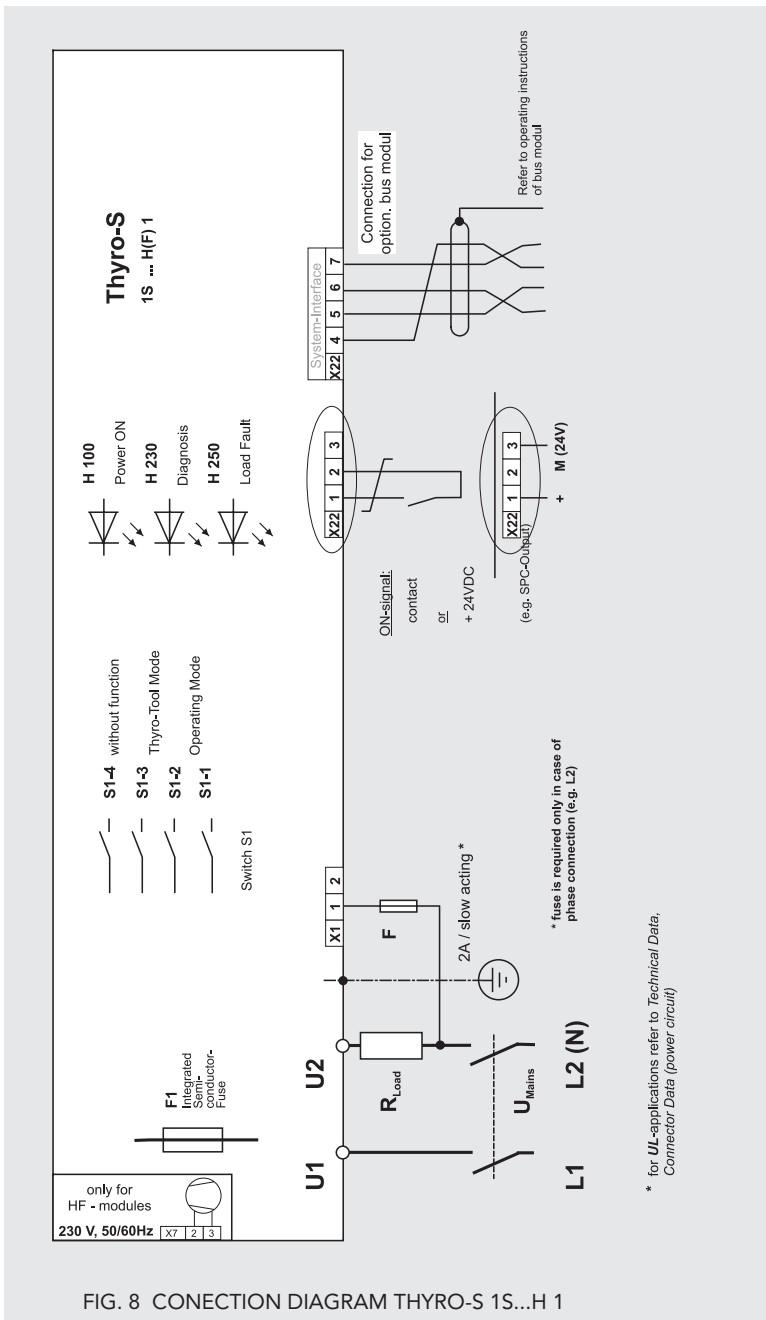

FIG. 8 CONECTION DIAGRAM THYRO-S 1S...H 1

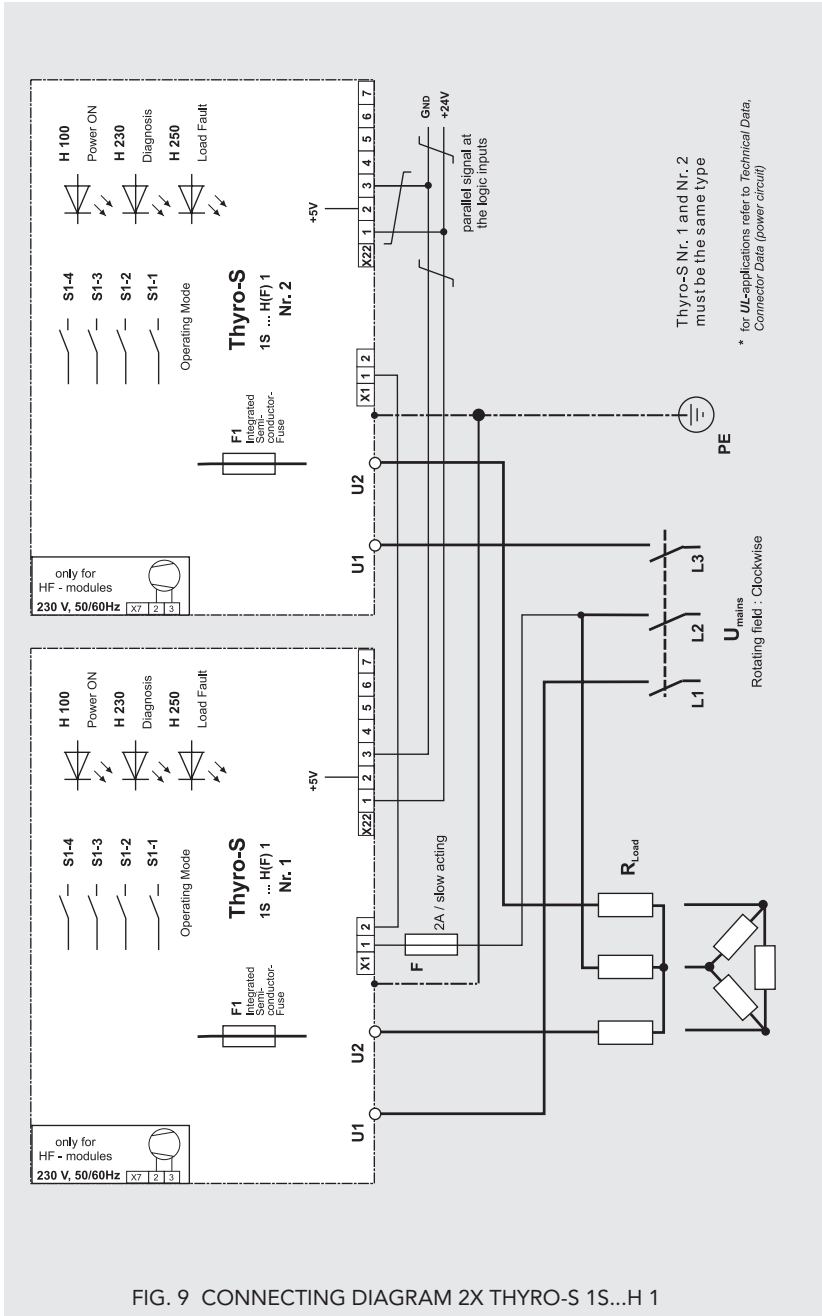

FIG. 9 CONNECTING DIAGRAM 2X THYRO-S 1S...H 1

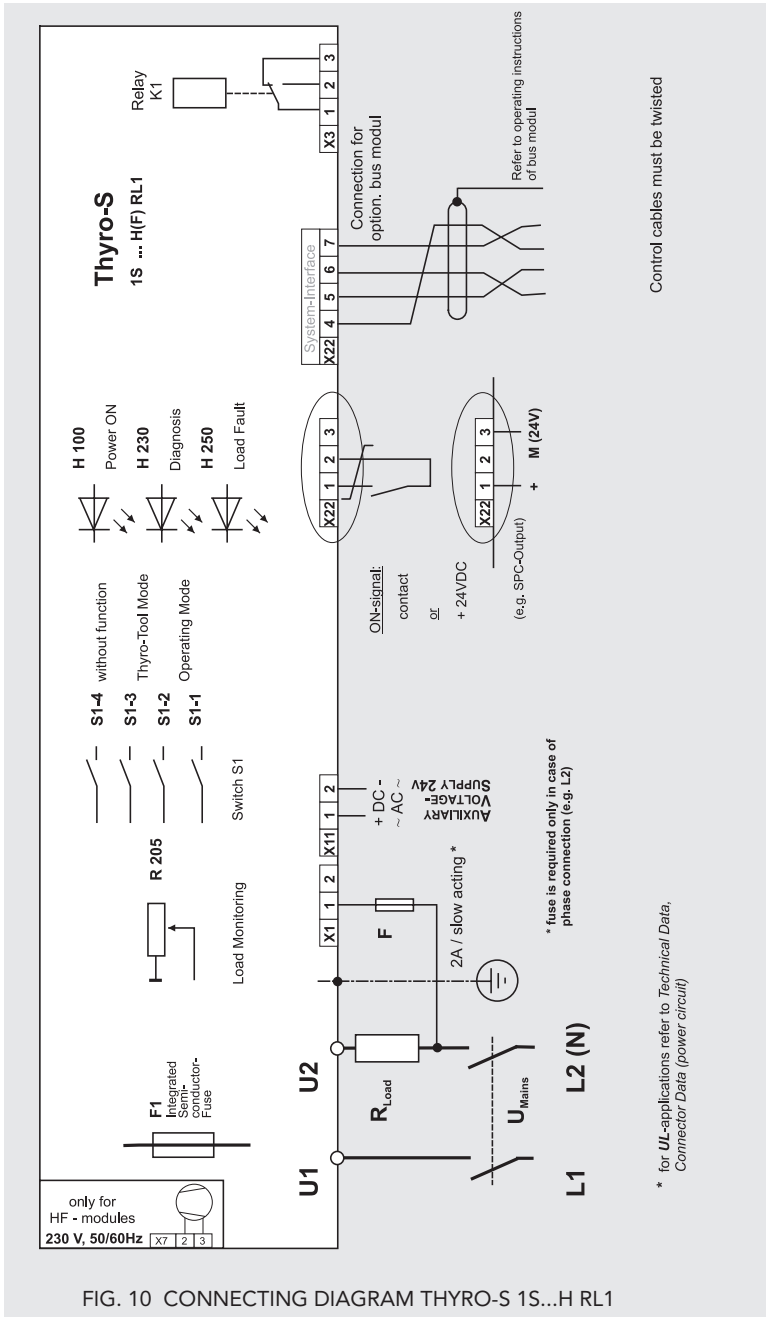
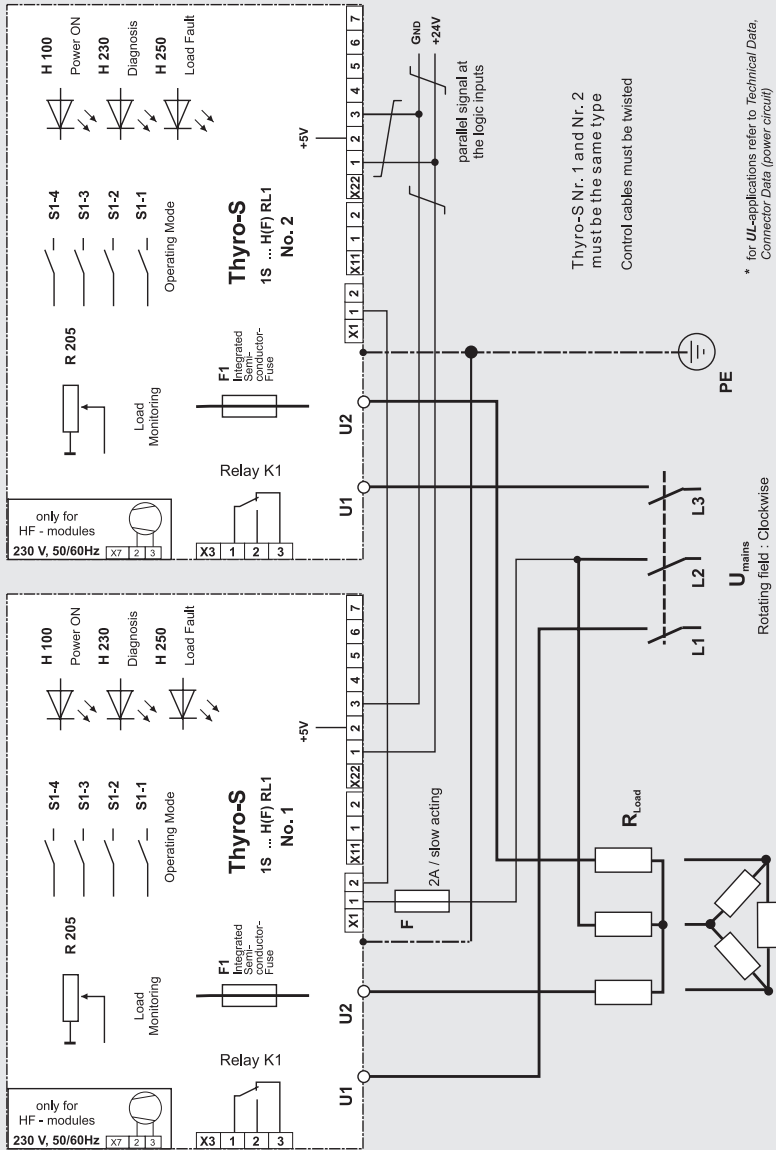

FIG. 10 CONNECTING DIAGRAM THYRO-S 1S...H RL1

Control cables must be twisted



* for UL-applications refer to Technical Data, Connector Data (power circuit)

FIG. 11 CONNECTING DIAGRAM 2X THYRO-S 1S...H RL1

8. SPECIAL REMARKS

8.1 INSTALLATION

Thyro-S requires a vertical fitting position. With cabinet mounting sufficient ventilation of the cabinet must be ensured. The distance between the Power Controller and the cabinet ceiling or other mountings should be at least 150 mm. The distance below the Power Controller should be at least 100 mm. The devices may be installed next to each other without lateral distance. Heating up of the device by heat sources must be avoided. The dissipation of the Power Controller is stated in the Type overview table.



ATTENTION

Grounding must be carried out according to local electricity board regulations! (grounding screw for protective conductor connection on fastening adapter is provided).

The grounding also serves EMV devices (Y capacitor 4.7 nF).

For Thyro-S with type currents up to 60A, adapters can be delivered for the 35 mm top-hat rail assembly.

8.2 COMMISSIONING

The device must be connected to the mains and the associated load according to the corresponding connecting plans.

On delivery the device is parameterized and adjusted to the respective power section. If a different operating mode is desired, then it must be set with DIP fix 1 and 2 by the user (commissioning phase).



ATTENTION

Heat sinks and neighbouring plastic parts can become hot during operation.

8.3 SERVICE

The devices delivered have been produced under quality standard ISO 9001.

Should nevertheless faults or problems occur, our technical contacts are at your service.

8.4 CHECKLIST

- LED ON lights up green -> mains voltage or supply voltage is available
- LED ON not lights up green
 - Check fusing of the power unit (built in semi-conductor fuse F1).
If the fuse is defective check load and wiring to load.
 - Check synchronisation voltage on X1.1
 - Check external back-up fuse
 - Check control fuse (F2) 500 V 1.6 A
 - With Thyro-S ...H RL 1 check 24 V (AC/DC) power supply where applicable
- Supply available but no load current
 - Check mains voltage
 - Switching on signal (digital set point, X22.1 versus X22.3 ≥ 3)
 - Check load circuit for interruptions
 - Check flashing LED signals (chapter 3.3)
- Load current does not have the expected value
 - Check switching on signal (digital set point) for continuous signal ON.
 - With optional bus module:
 - Check bus switching on signal (bus set point) for continuous signal ON.
 - Check all parallel load resistances for current flow.
- Load current is flowing without triggering
 - Check the wiring of the power unit (in case of first activating).
In very rare cases a thyristor short circuit may have occurred.

9. TYPE OVERVIEW

9.1 TYPE 1S...H 1

Thyristor switches with incorporated semiconductor fuse and system bus interface.

TYPE 1S	CURRENT	TYPE CAPACITY [KW]			DISSI- PATION [W]	DIMENSIONS IN MM / KG			WEIGHT	DIM. DRAW	FUSE F1
		230 V	400 V	500 V		W	H	E			
H 1	16	3.7	6.4	8	30	45	131	127	0.7	851	20
H 1	30	6.9	12	15	47	45	131	127	0.7	851	40
H 1	45	10	18	22.5	52	52	190	182	1.7	853	63
H 1	60	14	24	30	80	52	190	182	1.7	853	80
H 1	100	23	40	50	105	75	190	190	1.9	854	200
H 1	130	30	52	65	150	125	320	241	4	856	200
H 1	170	39	68	85	210	125	320	241	4	856	315
HF 1	280	64	112	140	330	125	370	241	5	858	350

9.2 TYPE 1S...H RL1

Thyristor switches with incorporated semiconductor, system bus interface, additional 24 V d.c./a.c. control voltage supply, relay indication and load current monitoring.

TYPE 1S	CURRENT	TYPE CAPACITY [KW]			DISSI- PATION [W]	DIMENSIONS IN MM / KG			WEIGHT	DIM. DRAW	CURRENT TRANSF.	FUSE F1
		230 V	400 V	500 V		W	H	E				
H RL 1	16	3.7	6.4	8	30	45	131	127	0.7	851	40	20
H RL 1	30	6.9	12	15	47	45	131	127	0.7	851	40	40
H RL 1	45	10	18	22.5	48	52	190	182	1.7	853	100	63
H RL 1	60	14	24	30	80	52	190	182	1.7	853	100	80
H RL 1	100	23	40	50	105	75	190	190	1.9	854	100	200
H RL 1	130	30	52	65	150	125	320	241	4	856	150	200
H RL 1	170	39	68	85	210	125	320	241	4	856	200	315
HF RL 1	280	64	112	140	330	125	370	241	5	856	300	350

10. TECHNICAL DATA

Type voltage

S..H1 230 Volt, 400 Volt, 500 Volt
– 57 % + 10 %;

S..HRL1 230 Volt – 15 % + 10 %;
> 99 V with additional 24 AC/DC electronic power

400 Volt – 15 % + 10 %;
> 172 V with additional 24 AC/DC electronic power

500 Volt – 15 % + 10 %;
> 215 V with additional 24 AC/DC electronic power

Mains frequency all models 47Hz to 63Hz; $\Delta=6\text{Hz}$;
max. frequency change 5% per half wave

Load description ohmic load

Operating modes	Name	Load signal, with digital set point = ON
	1:1	all full wave (default setting)
	1:2	every 2. mains full wave (DC free)
	1:3	every 3. mains full wave (DC free)
	1:5	every 4. mains full wave (DC free)

Digital set points inputs (connection signals)

The Thyro-S has 2 set point inputs. The set point inputs are safely disconnected from the mains (SELV, PELV).

Set point 1: Logic input 0-24 V $R_i > 3.3\text{k}\Omega$ ON > 3 V

Set point 2: System interface, connection from superset automation system via optional bus module.

Relay outputs using type 1S...H RL1

Changer, contact material: AgSnO₂ / Au plated

The relay can be used for low load circuits (> 5 V 20 mA), however not if it has been pre-loaded by 230 V AC.

Maximum values: 250 V 6 A, 180 W, 1500 VA

Insulation strength 4 kV / 8 mm

Ambient temperature

Max. surrounding air temperature 40 °C

45 °C natural air cooling (without fan)

If the maximum ambient temperature is reduced then the maximum load current can be increased up to 110% of the nominal current. In which case the following applies: 1% more current requires a temperature reduction of 1 °C. The maximum ambient temperature can be increased to a maximum of 55 °C, if the maximum load current is reduced. In which case the following applies: 1 °C more ambient temperature requires a current reduction of 2%. Use of devices for UL applications up to a maximum ambient temperature of 40 °C.

Power connections

Type current	Connector U1, U2,	Earthing screw	Conductor cross. sect
16 A	Lasche / M4	Lasche / M4	6 mm ² , max.
30 A	Lasche / M4	Lasche / M4	6 mm ² , max.
45 A*	M 6	M 6	50 mm ² , max.
60 A*	M 6	M 6	50 mm ² , max.
100 A*	M 6	M 6	50 mm ² , max.
130 A	M 8	M 10	95 / 120 mm ²
170 A	M 8	M 10	95 / 120 mm ²
280 A	M 10	M 10	150 / 185 mm ²

With UL applications only use 60 °C or 60 °C/75 °C copper conductors only (except for control circuit).

* With UL applications only use 75°C copper conductors (except for control circuit).

Torques for connection screws [Nm] and pound inches

Screw	Min value	Nom. value	Nom. value pound inches	Max value
M 2	0.22	0.25	2.2	0.28 (Phoenix terminals)
M 4	0.85	1.3	11.38	1.7
M 6	2.95	4.4	35.50	5.9
M 8	11.5	17	149	22.5
M10	22	33	289	44

Ventilation 230 V, 50-60 Hz

Thyro-S	Type current 50 Hz	Type current 60 Hz	Air volume	Noise level
1S 280 F	0.13 A	0.13 A	120 m ³ /h	67 dB(A)

The ventilators must run with Thyro-S switched on, connection to X7.

11. DIMENSIONAL DRAWINGS

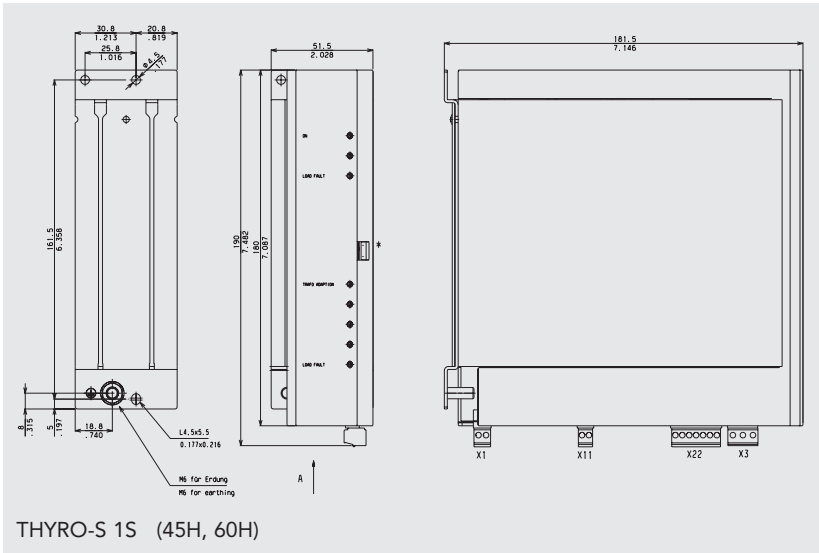
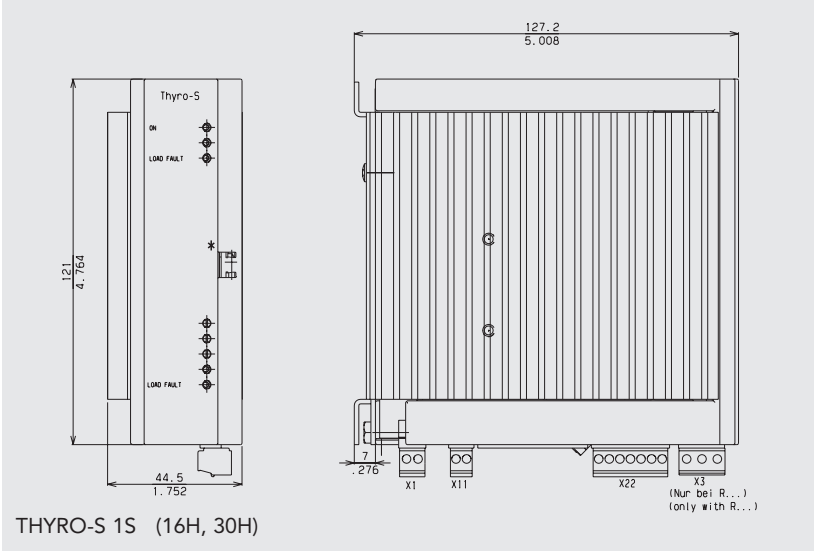

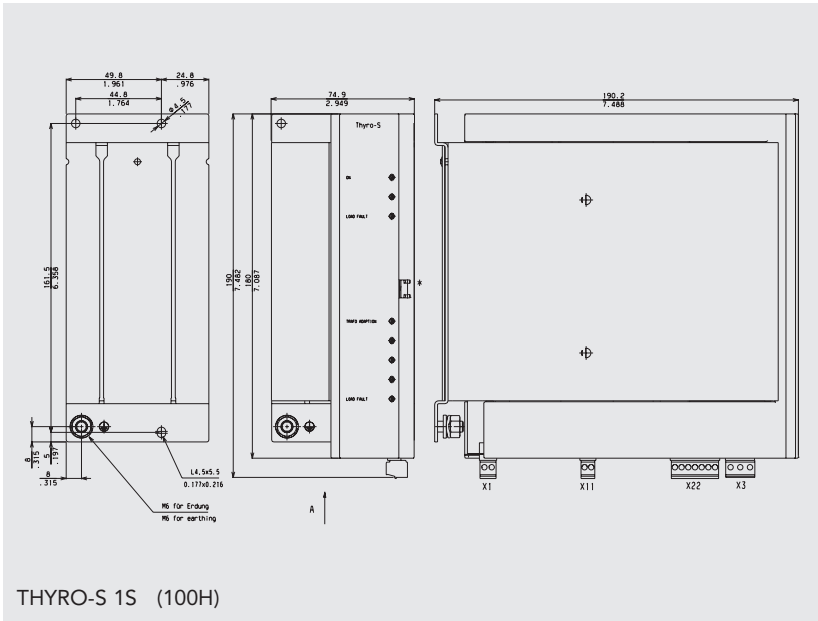

THYRO-S 1S (100H)

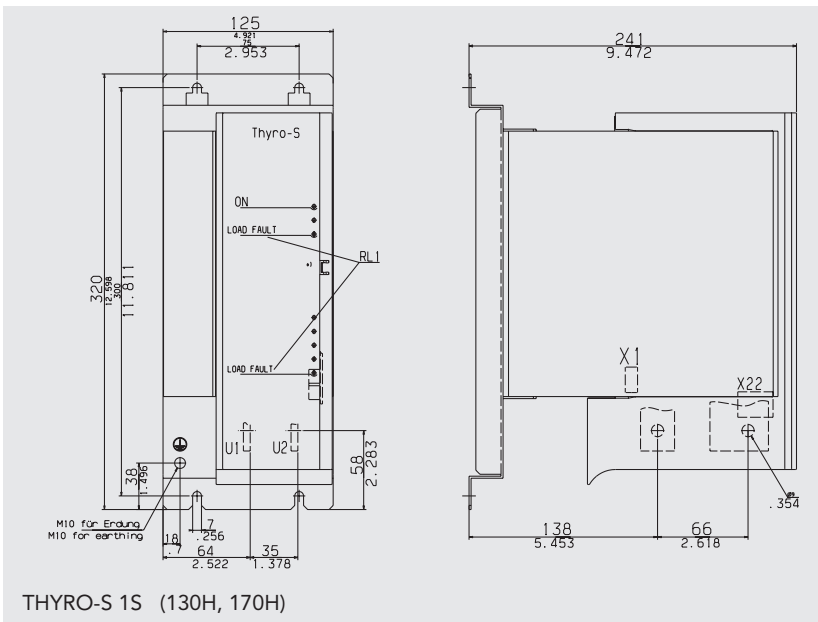

THYRO-S 1S (130H, 170H)

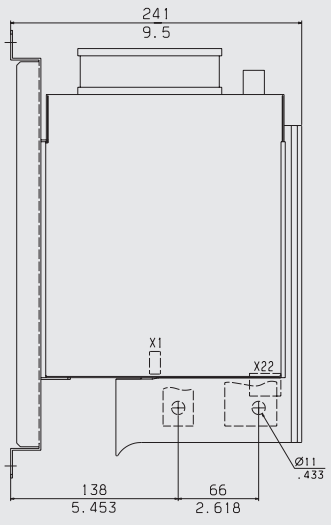
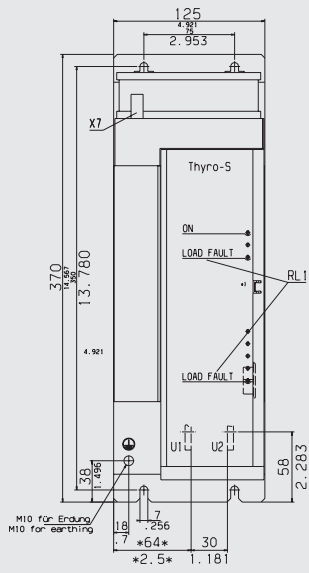

THYRO-S 1S (280H)

12. ACCESSORIES AND OPTIONS

Order no. 8.000.006.763	Support for 35 mm snap-on assembly 16 A and 30 A
Order no. 8.000.010.791	Support for 35 mm snap-on assembly for 45 A and 60 A
Order no. 2.000.000.380	PC Software Thyro-Tool Family
Order no. 2.000.000.845	PC interface RS232 (RS232 data line or adapter cables USB1.1 to RS232 additionally required)
Order no. 6000016474	RS232 data line
Order no. 8000019086	Adapter-cable USB1.1 to RS-232
Order no. 2.000.000.841	Bus module Profibus-DP
Order no. 2.000.000.842	Bus module Modbus RTU
Order no. 2.000.000.843	Bus module CANopen
Order no. 2.000.000.844	Bus module DeviceNet
Order no. 2.000.000.846	Busmodule Ethernet (Profinet, EtherNet IP, Modbus TCP)
Order no. 2.000.000.848	Bus module connector cable for 4 controllers, 2.5 m long
Order no. 2.000.000.849	Bus module connector cable for 4 controllers, 1.5 m long

13. APPROVALS AND CONFORMITIES

No product norm exists for Thyristor switches so that a useful norm structure can be built up based on the corresponding basic norms ensuring reliable application and comparison potential.



CAUTION

Thyristor switches are not devices for disconnection in the sense of EN 50110-1 and may therefore be operated only in connection with a suitable mains isolating device (e.g. switch, isolating link).

Approvals and conformities for Thyro-S are available

- Quality standard according to EN ISO 9001
- UL registration, file no. E 135074, with consideration to Canadian National Standard C 22.2 No. 14-95
- UL Markings:
 - Tightening torque (in pound inches) see Chapter 10.
„Technical data“
 - Use 75°C Copper Conductors only (except for control circuits)
 - „Max. surrounding air temperature 40°C“
 - Suitable For Use On A Circuit Capable Of Delivering Not More Than 100kA rms Symmetrical Amperes, xxx Volts Maximum, When Protected by RK5 Class Fuses“



NOTE:

xxx = max. allowable voltage depending upon rating of the device

- „Branch circuit protection must be provided and sized according National Electrical Code and any additional local codes“
- CE conformity
- Low voltage directive 2006/95/EG
- EMV directive 2004/108/EG
- RoHS compliant 5/6

IN DETAIL

CONDITIONS FOR USEN

Built-in unit (VDE 0160)		EN 50 178
General requirements		EN 60146-1
Design, vertical installation		
Operating conditions		EN 60 146-1-1; K. 2.5
Operating location, industry sector		CISPR 6
Temperature behaviour		EN 60 146-1-1; K 2.2
Storage temperature		-25 °C - +55 °C
Transport temperature		-25 °C - +70 °C
Operating temperature		-10 °C - +40 °C with external cooling (280A)
		-10 °C - +45 °C with self air cooling
		-10 °C - +55 °C with reduced type current -2%/°C
Load class	1	EN 60 146-1-1 T.2
Humidity class	F	EN 50 178 Tab. 7
Overvoltage category	ÜIII	EN 50 178 Tab. 3
Degree of pollution	2	EN 50 178 Tab. 2
Air pressure		900 mbar * 1000 m above NN
Safe isolation up to 500 V mains voltage		EN 50 178 Chap. 3
Air and creeping distances according to EN 50178 Tab. 2 and 3		casing / mains potential > 5.5 mm casing / control potential > 2.5 mm mains voltage /contr. potent. ≥ 10 mm interface /contr. Potent. -/- mains voltages interact 2.5 mm
Test voltage		EN 50 178 Tab. 18
Tests according to		EN 60 146-1-1 4.
EMV noise emission		EN 61000-6-4
Noise suppr. control device	Class A	EN 55011 CISPR 11
EMV noise resistance		EN 61000-6-2
Compatibility level	Class 3	EN 61000-2-4
ESD	8 kV (A)	EN 61000-4
Electromagnetic fields	10 V/m	EN 61000-4
Burst mains lines	2 kV (A)	EN 61000-4-5
control lines	2 kV (A)	
Surge mains lines	2 kV unsym. 1 kV sym.	EN 61000-4 EN 61000-4
control lines	0,5 kV	
Line-conducted		EN 61000-4-6



World Headquarters
1625 Sharp Point Drive
Fort Collins, CO 80525 USA
970.221.4670 Main
970.221.5583 Fax

www.advanced-energy.com

Specifications are subject to change without notice.

© 2014 Advanced Energy Industries, Inc. All rights reserved. Advanced Energy® and Thyro-S are trademarks of Advanced Energy Industries, Inc.

