

# Absolute encoders - SSI

## Solid shaft with clamping or synchro flange

### Optical multiturn encoders 18 bit ST / 12 bit MT

#### GBM2W



GBM2W with clamping flange

#### Technical data - electrical ratings

Voltage supply	10...30 VDC
Reverse polarity protection	Yes
Consumption w/o load	≤50 mA (24 VDC)
Initializing time typ.	20 ms after power on
Interfaces	SSI, Incremental A 90° B (optional)
Function	Multiturn
Steps per turn	262144 / 18 bit
Number of turns	4096 / 12 bit
Absolute accuracy	±0.01 °
Sensing method	Optical
Code	Gray or binary
Code sequence	CW/CCW coded by connection
Inputs	SSI clock: RS422 Control signals UP/DOWN inv. and zero
Output stages	SSI data: RS422 Diagnostic outputs push-pull
Incremental output	2048 pulses A90°B + inverted
Interference immunity	DIN EN 61000-6-2
Emitted interference	DIN EN 61000-6-4
Diagnostic functions	Self-diagnosis Multiturn sensing
Approval	UL approval / E63076

#### Features

- High resolution encoder multiturn / SSI
- Optical sensing method
- Resolution: singleturn 18 bit, multiturn 12 bit
- Electronic setting of zero point
- Counting direction input
- Available with additional incremental output
- Maximum resistant against magnetic fields

#### Optional

- Stainless steel design
- Corrosion protection for offshore applications
- Extended operating temperature range up to -40 °C

#### Technical data - mechanical design

Size (flange)	ø58 mm
Shaft type	ø10 mm solid shaft (clamping flange) ø6 mm solid shaft (synchro flange)
Flange	Clamping or synchro flange
Protection DIN EN 60529	IP 54 (without shaft seal), IP 65 (with shaft seal)
Operating speed	≤10000 rpm (mechanical) ≤6000 rpm (electric)
Starting acceleration	≤1000 U/s <sup>2</sup>
Starting torque	≤0.015 Nm (+25 °C, IP 54) ≤0.03 Nm (+25 °C, IP 65)
Rotor moment of inertia	20 gcm <sup>2</sup>
Admitted shaft load	≤20 N axial ≤40 N radial
Materials	Housing: steel Flange: aluminium
Operating temperature	-25...+85 °C -40...+85 °C (optional)
Relative humidity	95 % non-condensing
Resistance	DIN EN 60068-2-6 Vibration 10 g, 16-2000 Hz DIN EN 60068-2-27 Shock 200 g, 6 ms
Weight approx.	400 g
Connection	Connector M23, 12-pin Cable 1 m

· Subject to modification in technic and design. Errors and omissions excepted.

# Absolute encoders - SSI

## Solid shaft with clamping or synchro flange

### Optical multiturn encoders 18 bit ST / 12 bit MT

**GBM2W**

#### Part number

GBM2W.

#### Pulses / Incremental output

- 02 No incremental output
- 04 2048 pulses / push-pull
- 06 2048 pulses / RS422
- 07 2048 periods / SinCos

#### Connection

- A0 Connector M23, 12-pin, axial
- A1 Connector M23, 12-pin, radial
- A2 Connector M23, 12-pin, axial, for incremental output 04/06/07
- A3 Connector M23, 12-pin, radial, for incremental output 04/06/07
- 11 Cable 1 m, axial
- 21 Cable 1 m, radial
- 31 Cable 1 m, axial, for incremental output 04/06/07
- 41 Cable 1 m, radial, for incremental output 04/06/07

#### Voltage supply / signals

- 10 10...30 VDC / gray code 30 bit
- 12 10...30 VDC / binary code 30 bit

#### Flange / Solid shaft

- 0 Clamping flange /  $\varnothing$ 10 mm, IP 54
- A Clamping flange /  $\varnothing$ 10 mm, IP 65
- 1 Synchro flange /  $\varnothing$ 6 mm, IP 54
- B Synchro flange /  $\varnothing$ 6 mm, IP 65

#### Accessories

##### Connectors and cables

11034154	Female connector M23, 12-pin, without cable (Z 130.001)
10138559	Female connector M23, 12-pin, 2 m cable (Z 130.003)
10126594	Female connector M23, 12-pin, 5 m cable (Z 130.005)
10129757	Female connector M23, 12-pin, 10 m cable (Z 130.007)
11034344	Female connector M23, 12-pin, without cable (incr.) (Z 182.001)
11034345	Female connector M23, 12-pin, 2 m (incr.) (Z 182.003)
11034346	Female connector M23, 12-pin, 5 m (incr.) (Z 182.005)
11034347	Female connector M23, 12-pin, 10 m (incr.) (Z 182.007)

##### Mounting accessories

10117669	Eccentric fixing, single (Z 119.006)
10141255	Adaptor plate for clamping flange for modification into synchro flange (Z 119.013)
10117667	Mounting adaptor for encoders with synchro flange (Z 119.015)
10125051	Mounting adaptor for encoders with clamping flange (M3) (Z 119.017)

· Subject to modification in technic and design. Errors and omissions excepted.

# Absolute encoders - SSI

## Solid shaft with clamping or synchro flange

### Optical multiturn encoders 18 bit ST / 12 bit MT

#### GBM2W

##### Data transfer

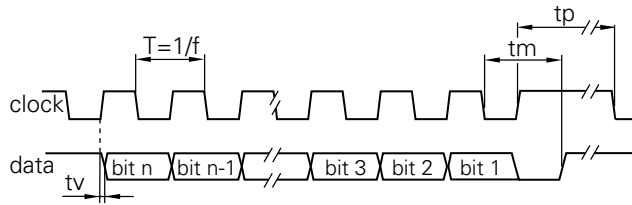

Clock frequency f	62.5...1500 kHz
Duty cycle of T	40...60 %
Delay time tv	150 ns
Monoflop time tm	26 μs + T/2
Clock interval tp	30 μs

##### Trigger level

SSI	Circuit
SSI-Clock	RS422 Terminating resistor 220 Ω
SSI-Data	RS422

Control inputs	Input circuit
Input level High	>0.7 UB
Input level Low	<0.3 UB
Input resistance	10 kΩ

Diagnostic outputs or Incremental outputs	Output circuit Push-pull circuit-proof
Output level High	>UB -3.5 V (I = -20 mA)
Output level Low	<0.5 V (I = 20 mA)
Load High / Low	<20 mA

Incremental outputs	Linedriver RS422
Output level High	>2.5 V (I = -20 mA)
Output level Low	<0.5 V (I = 20 mA)
Load High / Low	<20 mA

Outputs	SinCos
Output level	1 Vpp ±10 %
Load	<10 mA

# Absolute encoders - SSI

## Solid shaft with clamping or synchro flange

### Optical multiturn encoders 18 bit ST / 12 bit MT

**GBM2W**

Terminal significance	
UB	Encoder voltage supply.
GND	Encoder ground connection relating to UB.
Data+	Positive, serial data output of differential linedriver.
Data-	Negative, serial data output of differential linedriver.
Clock+	Positive, serial clock input of differential RS422 receiver.
Clock-	Negative, serial clock input of differential RS422 receiver.
Zero setting	Input for setting a zero point anywhere within the programmed encoder resolution. The zero setting operation is triggered by a High impulse and has to be in line with the selected direction of rotation (UP/DOWN). Connect to GND after setting operation for maximum interference immunity. Impulse duration $\geq 100$ ms.
DATAVALID	Diagnostic output. An error warning is given at level Low. Important: Interferences must be drained by the downstream electronics.
DATAVALID MT	Diagnostic output for monitoring the multiturn sensor voltage supply. Upon dropping below a defined voltage level the DV MT output is switched to Low.
UP/DOWN	UP/DOWN counting direction input. This input is standard on High. UP/DOWN means ascending output data with clockwise shaft rotation when looking at flange. UP/DOWN-Low means ascending values with counterclockwise shaft rotation when looking at flange.
Incremental Outputs	Incremental tracks A 90° B and inverted.

Terminal assignment		
GBM2W		
Connector	Core colour	Assignment
Pin 1	brown	UB
Pin 2	black	GND
Pin 3	blue	Clock+
Pin 4	beige	Data+
Pin 5	green	Zero setting
Pin 6	yellow	Data-
Pin 7	violet	Clock-
Pin 8	brown/yellow	DATAVALID
Pin 9	pink	UP/DOWN
Pin 10	black/yellow	DATAVALID MT
Pin 11-12	–	–

#### GBM2W with incremental tracks | SinCos

Connector	Core colour	Assignment	SinCos
Pin 1	brown	UB	UB
Pin 2	white	GND	GND
Pin 3	blue	Clock+	Clock+
Pin 4	green	Data+	Data+
Pin 5	grey	Zero setting	Zero setting
Pin 6	yellow	Data-	Data-
Pin 7	red	Clock-	Clock-
Pin 8	red/blue	Track B inv.	Cosine
Pin 9	pink	UP/DOWN	UP/DOWN
Pin 10	violet	Track A inv.	Sine
Pin 11	black	Track A	Sine
Pin 12	grey/pink	Track B	Cosine

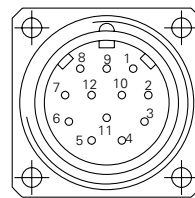

Please use cores twisted in pairs (for example clock+ / clock-) for extension cables of more than 10 m length.

· Subject to modification in technic and design. Errors and omissions excepted.

# Absolute encoders - SSI

## Solid shaft with clamping or synchro flange

### Optical multiturn encoders 18 bit ST / 12 bit MT

## GBM2W

### Dimensions

#### GBM2W - clamping flange

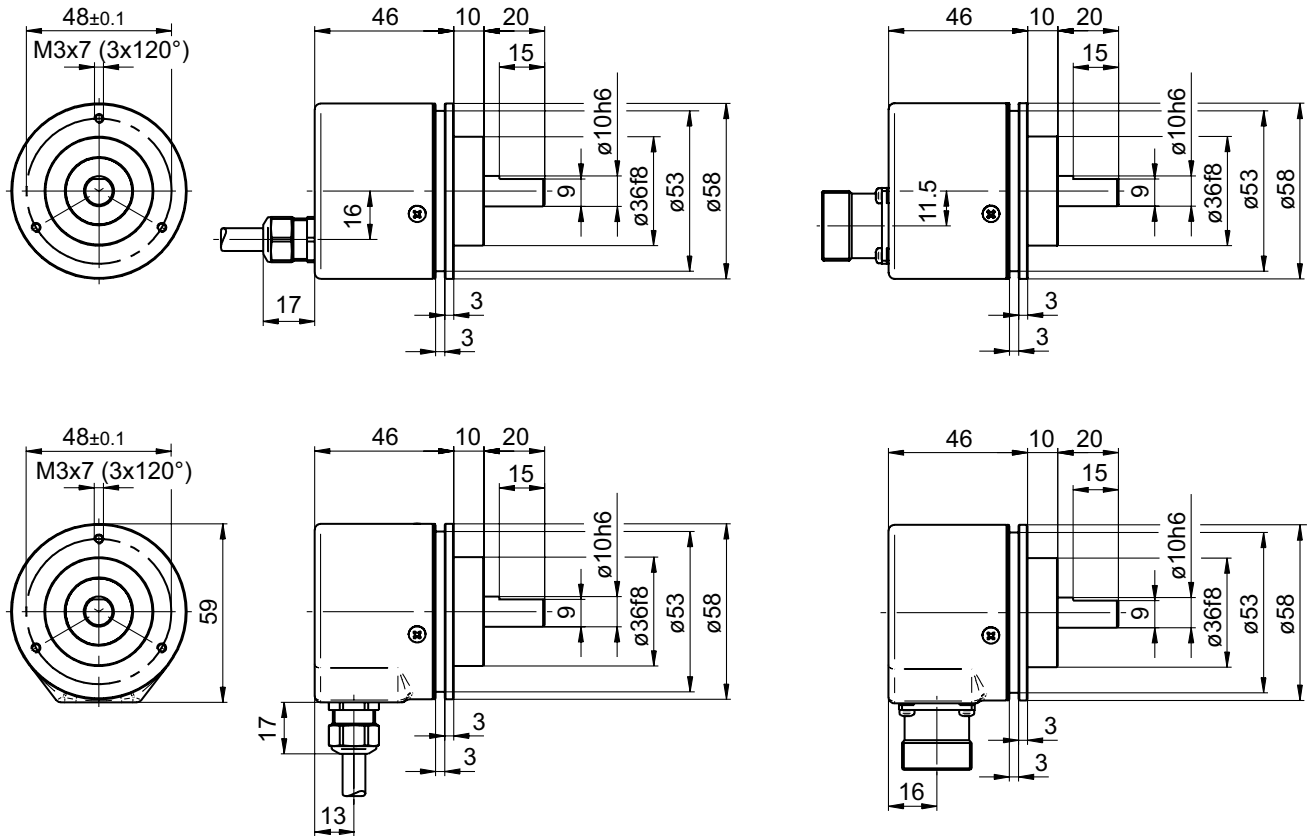

#### GBM2W - synchro flange

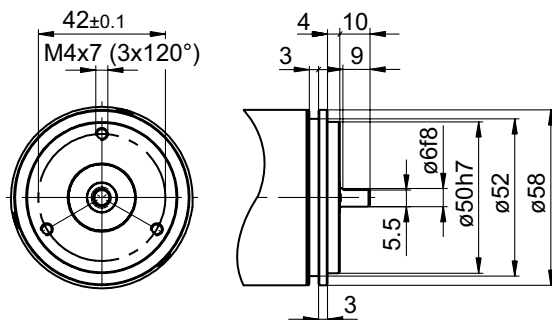

#### GBM2W - connector dimensions

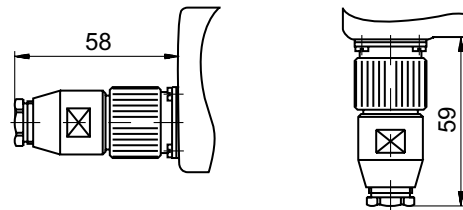

· Subject to modification in technic and design. Errors and omissions excepted.