

# Tachometer electronic

## Rotation speed ratio display

### Large 14 mm display LED, 6-digits, programmable

#### TA201



TA201 - LED-Tachometer

#### Technical data - electrical ratings

Voltage supply	115/230 VAC $\pm 10\%$ (50/60 Hz) 24/48 VAC $\pm 10\%$ (50/60 Hz) 24 VDC $\pm 10\%$
Power consumption	7 VA, 5 W
Sensor supply	12...26 VDC / max. 100 mA
Display	LED, 7-segment display
Number of digits	6-digits
Digit height	14 mm
Unit displayed	1/s, 1/min, 1/h programmable
Function	Tachometer for 2 measured values and calculator function
Measuring principle	Period duration measurement
Calculating functions	Difference F1-F2 Ratio F1:F2 Stretch-/shrinking (F2-F1):F1 Flow Pulse rate measurement
Signal inputs	Comparator inputs
Input logic	NPN / PNP
Control inputs	2 Inputs
Control functions	Start, Stop
Counting frequency	F1: 10 kHz / F2: 25 Hz, 40 kHz
Scaling factor	0.0001...9999.99
Data memory	>10 years in EEPROM
Standard DIN EN 61010-1	Protection class II Overvoltage category II Pollution degree 2
Emitted interference	DIN EN 61000-6-3
Interference immunity	DIN EN 61000-6-2
Programmable parameters	Assignment F1, F2 or F3 Calculating functions Count frequency
Approvals	UL/cUL, CE conform

#### Features

- Tachometer for two rotation speeds and velocity
- Display 6-digits
- Connection: Two one-channel digital sensors or potential-free contacts
- Ratio display
- Impulse evaluation programmable
- Input F1 with phase evaluation
- Period duration measurement

#### Description

Two tachos to capture and display for example rotation speed and velocity by "F1" and "F2" as well as an operator-programmed calculating function that can be selected and displayed by "F3". The calculating function may be used for example to evaluate ratio, difference, stretching/shrinking, flow, time elapsed with start and stop signal, impulse rate measurement, period or impulse duration.

#### Technical data - mechanical design

Operating temperature	0...+50 °C
Storing temperature	-20...+70 °C
Relative humidity	80 % non-condensing
E-connection	Plug-in screw terminals
Core cross-section	1.5 mm <sup>2</sup>
Protection DIN EN 60529	IP 65 face with seal
Operation / keypad	Membrane with softkeys
Housing type	Housing for control panel installation
Dimensions W x H x L	96 x 48 x 124 mm
Cutout dimensions	93 x 45 mm (+0.6)
Installation depth	123.75 mm
Mounting	Front panel installation by clip frame
Weight approx.	350 g (AC), 250 g (DC)
Material	Housing: Makrolon 6485 (PC)

# Tachometer electronic

## Rotation speed ratio display

### Large 14 mm display LED, 6-digits, programmable

TA201

#### Part number

TA201.00 AXA1

- Voltage supply
- 1 24 / 48 VAC
  - 2 115 / 230 VAC
  - 3 24 VDC

#### Connection diagram

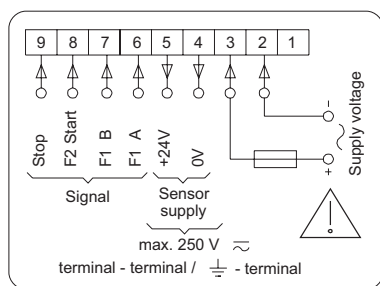

#### Block circuit diagram

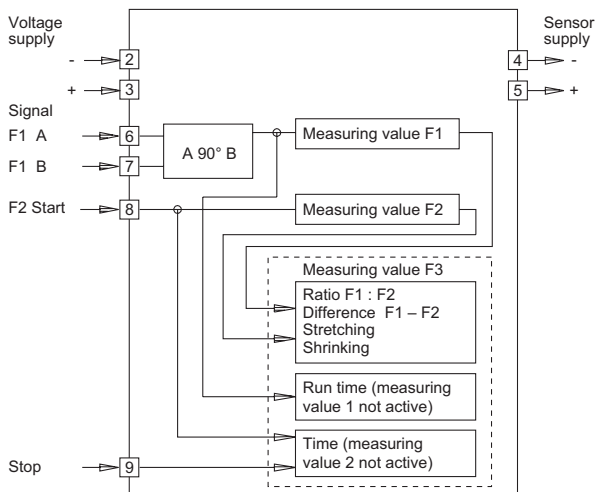

#### Trigger level

Comparator input	Input circuit
Inputs	PNP- / NPN-logic
Input level	Programmable
Input level Low	0...2 VDC
Input level High	3...40 VDC
Input resistance	3 kΩ

#### Dimensions

