

Incremental encoders

End shaft max. $\varnothing 14$ mm

Resolution 5...6000 pulses

GI330, GI332



GI330 with end shaft

Technical data - electrical ratings

Voltage supply	5 VDC ± 10 % 4.75...30 VDC
Reverse polarity protection	Yes (4.75...30 VDC)
Consumption w/o load	≤ 30 mA (24 VDC) ≤ 60 mA (5 VDC)
Resolution (steps/turn)	5...6000
Reference signal	Zero pulse, width 90°
Sensing method	Optical
Output frequency	≤ 150 kHz
Output signals	A 90° B, N + inverted
Output circuit	Linedriver RS422 Push-pull short-circuit proof
Interference immunity	DIN EN 61000-6-2
Emitted interference	DIN EN 61000-6-4
Approval	UL approval / E63076

Features

- Encoder with end shaft max. $\varnothing 14$ mm
- Optical sensing
- Resolution max. 6000 ppr
- Center mounting or by clamping ring
- Cost-efficient mounting

Technical data - mechanical design

Housing	$\varnothing 58$ mm
Protection DIN EN 60529	IP 54
Operating speed	≤ 6000 rpm
Starting torque	≤ 0.03 Nm
Rotor moment of inertia	14.5 gcm ²
Materials	Housing: aluminium Flange: aluminium
Operating temperature	-25...+100 °C (5 VDC) -25...+85 °C (24 VDC)
Relative humidity	95 % non-condensing
Resistance	DIN EN 60068-2-6 Vibration 10 g, 16-2000 Hz DIN EN 60068-2-27 Shock 200 g, 6 ms
Weight approx.	250 g
Connection	Connector or cable

GI330

Shaft	$\varnothing 12$ mm end shaft
-------	-------------------------------

GI332

Shaft	$\varnothing 12$ mm end shaft $\varnothing 14$ mm end shaft
-------	--

Incremental encoders

End shaft max. \varnothing 14 mm

Resolution 5...6000 pulses

GI330, GI332

Part number

End shaft with center mounting

GI330.

See part number (pulses)

Connection

C3 Connector M23, 12-pin, radial
41 Cable 1 m, radial

Voltage supply / signals

22 5 VDC / linedriver RS422
70 4.75...30 VDC / push-pull
72 4.75...30 VDC / linedriver RS422 (5 VDC)

Hollow shaft / torque pin

- 0 End shaft \varnothing 12 mm center mounting with pin 15 mm
- 1 End shaft \varnothing 12 mm center mounting with pin 9.5 mm
- A End shaft \varnothing 12 mm center mounting without pin

End shaft with clamping ring

GI332.

See part number (pulses)

Connection

C3 Connector M23, 12-pin, radial
41 Cable 1 m, radial

Voltage supply / signals

22 5 VDC / linedriver RS422
70 4.75...30 VDC / push-pull
72 4.75...30 VDC / linedriver RS422 (5 VDC)

Hollow shaft / torque pin

- 0 End shaft \varnothing 12 mm clamping ring on flange with pin 15 mm
- 1 End shaft \varnothing 12 mm clamping ring on flange with pin 9.5 mm
- A End shaft \varnothing 12 mm clamping ring on flange without pin
- 4 End shaft \varnothing 14 mm clamping ring on flange with pin 15 mm
- 5 End shaft \varnothing 14 mm clamping ring on flange with pin 9.5 mm

Part number (pulses)

49 (5)	57 (128)	22 (1000)	31 (3600)
36 (10)	06 (200)	23 (1024)	34 (4096)
50 (25)	09 (250)	24 (1250)	35 (5000)
39 (50)	13 (360)	26 (1500)	48 (6000)
40 (60)	14 (400)	28 (2000)	
41 (100)	15 (500)	30 (2500)	

Other pulse numbers upon request.

Example: order key 23 = 1024 pulses

Accessories

Connectors and cables

Z 141.001	Female connector M23, 12-pin, less cable
Z 141.003	Female connector M23, 12-pin, 2 m cable
Z 141.005	Female connector M23, 12-pin, 5 m cable
Z 141.007	Female connector M23, 12-pin, 10 m cable

Mounting accessories

Z 119.023	Spring coupling for encoders with \varnothing 58 mm housing
Z 119.024	Torque support and spring washer for encoders with 9.5 mm pin
Z 119.041	Torque support by rubber buffer element for encoders with 15 mm pin

Incremental encoders

End shaft max. $\varnothing 14$ mm

Resolution 5...6000 pulses

GI330, GI332

Output signals

Clockwise rotating direction when looking at flange.

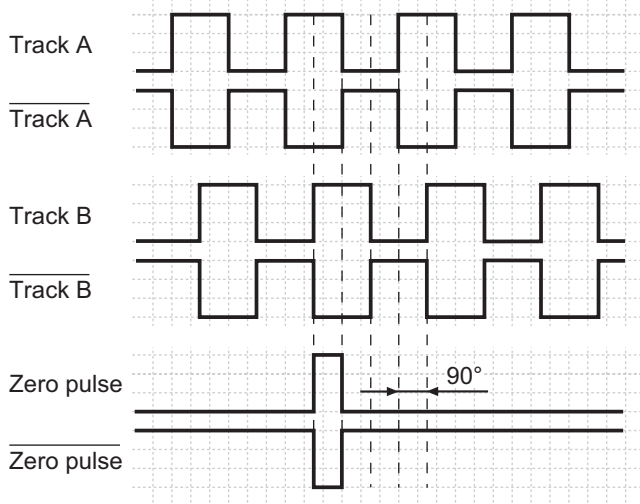

Terminal assignment

Connector	Core colour	Assignment
Pin 1	pink	Track B inv.
Pin 2	blue	UB-Sense
Pin 3	red	Track N (zero pulse)
Pin 4	black	Track N inv. (zero pulse inv.)
Pin 5	brown	Track A
Pin 6	green	Track A inv.
Pin 7	–	–
Pin 8	grey	Track B
Pin 9	–	–
Pin 10	white/green	GND
Pin 11	white	GND-Sense
Pin 12	brown/green	UB

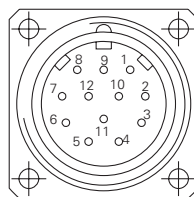

UB-Sense and GND-Sense are directly connected to UB resp. GND. Please use cores twisted in pairs (for example track A / track A inv.) for extension cables of more than 10 m length.

Trigger level

Outputs	Linedriver RS422
Output level High	>2.5 V (I = -20 mA)
Output level Low	<0.5 V (I = 20 mA)
Load High	<20 mA
Load Low	<20 mA

Outputs	Push-pull short-circuit proof
Output level High	>UB -3 V (I = -20 mA)
Output level Low	<0.5 V (I = 20 mA)
Load High	<20 mA
Load Low	<20 mA

Incremental encoders

End shaft max. $\varnothing 14$ mm

Resolution 5...6000 pulses

GI330, GI332

Dimensions

GI330 end shaft and center mounting

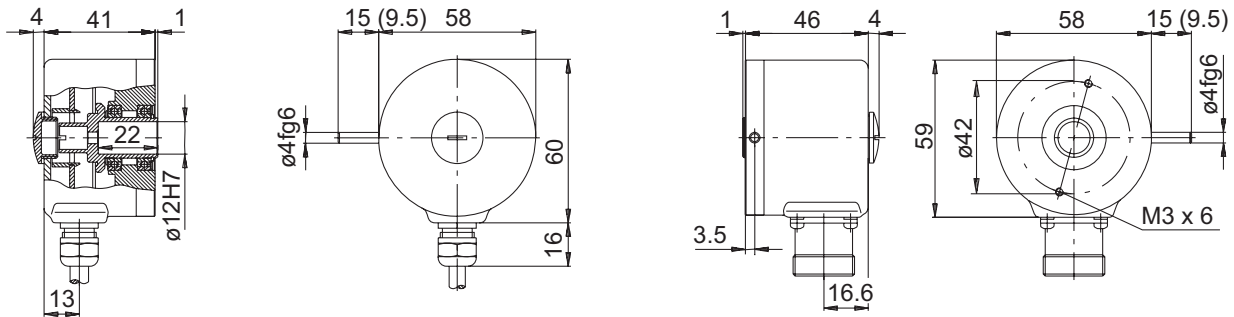

GI332 end shaft and clamping ring on flange

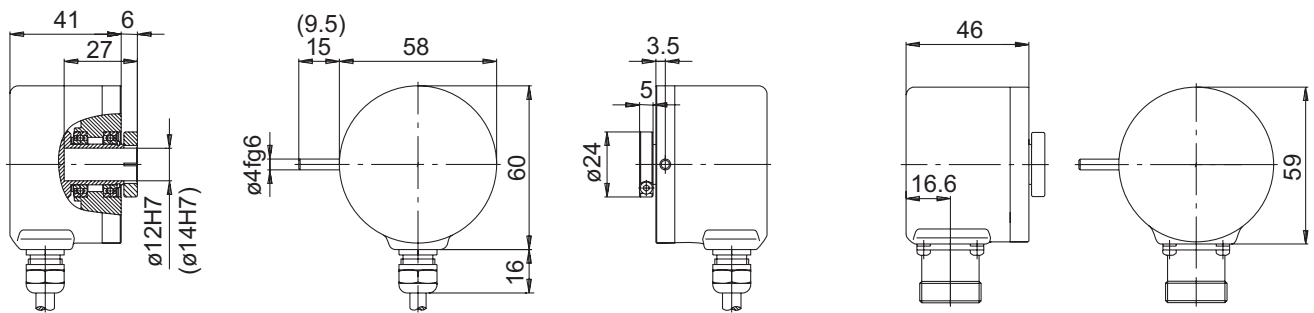

GI330, GI332 connector dimensions

