

Accessories

Mounting accessories

Z 119.076



Features

- Several graduated circle options for mounting on the intended surface
- For low-dynamic applications

Description

Spring coupling mount is for low-dynamic applications. Mount Spring coupling at flange by help of the attached screws. Push encoder onto drive shaft and fix the torque support at the contact surface.

Part number

Z 119.076 Spring coupling for encoders with $\varnothing 58$ mm housing

Scope of delivery

Included: spring coupling, two screws M3 x 12 with two spacer sleeves

Suitable for

G0A2H, G0AMH, G0L2H, G0LMH, G0M2H, G0MMH, G0P5H, GBA2H, GBA2S, GBAMH, GBAMS, GBMMH, GBMMS, GBP5H, GEMMH, GXA2S, GXAMS, GXL2S, GXLMS, GXM2S, GXM7S, GXMMS, GXP5S

Dimensions

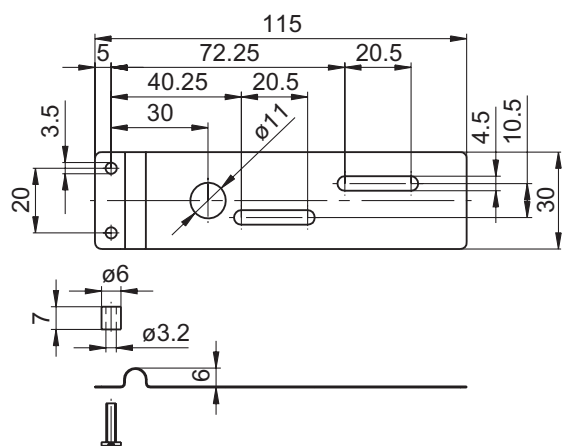

Dimension

