

Spindle position displays

Hollow shaft max. $\varnothing 25$ mm, automated format alignment

Display LCD two lines, interface RS485

N 142



N 142 with cable output

Features

- Automated format alignment
- Two keys for format alignment touch by touch
- Hollow shaft $\varnothing 20$ mm / $\varnothing 25$ mm
- Resolution: 2304 steps/revolution ± 4096 revolutions
- Display: LCD backlit, two lines
- Absolute multiturn measuring system
- Actual value and target display
- Interface RS485

Technical data - electrical ratings

Voltage supply	24 VDC ± 10 %
Current consumption	≤ 40 mA
Display	LCD, 7-segment display, 2-lines, backlit
Measuring principle	Absolute multiturn measuring system
Measuring range	-999,99...+9999,99 mm -99.999...+999.999 inch
Steps per turn	2304
Number of turns	4096 / 12 bit
Spindle pitch	≤ 23 mm
Interface	RS485 (ASCII protocol)
Data memory	Parameter buffer: EEPROM Current value buffer: >10 years by integrated 3 V lithium battery
Programmable parameters	Display position horizontal/vertical Measuring unit mm/inch Counting direction Spindle pitch Spindle tolerance Positioning direction Direction arrows Tolerance window Round up/down
Motive positioning	Two softkeys for format alignment Direct motor connection to N 142 by motor cable
Standard DIN EN 61010-1	Protection class II Overvoltage category II Pollution degree 2
Emitted interference	DIN EN 61000-6-3
Interference immunity	DIN EN 61000-6-2
Approval	UL approval / E63076

Technical data - mechanical design

Shaft	$\varnothing 20$ mm hollow shaft $\varnothing 25$ mm hollow shaft
Operating speed	≤ 600 rpm (short-term)
Protection DIN EN 60529	IP 65 (housing), IP 40 (connector)
Operating temperature	-10...+50 °C
Storing temperature	-20...+70 °C
Relative humidity	80 % non-condensing
Torque support	Torque pin provided at housing
Connection	- Cable output (30 cm) with male/female connector M16, 5-pin - Motor cable with female connector M16, 12-pin
Operation / keypad	Membrane with two keys
Housing type	Surface-mount with hollow shaft
Dimensions W x H x L	56 x 100 x 62.5 mm
Mounting	Surface-mount with hollow shaft
Weight approx.	200 g
Material	Polycarbonate black, UL 94V-0

Spindle position displays

Hollow shaft max. $\varnothing 25$ mm, automated format alignment

Display LCD two lines, interface RS485

N 142

Part number

N 142. 1 3 A 01

				Hollow shaft
			A	Hollow shaft $\varnothing 25$ mm
			B	Hollow shaft $\varnothing 20$ mm
				Display
			A	Inclined
				Voltage supply
		3		24 VDC
				Connection
	1			Cable output M16, motor cable 0.5 m
	2			Cable output M16, motor cable 1.5 m
				Interface
1				RS485

Description

multiconDrive represents a simplified and very efficient, reasonably priced system for automatic format alignment. With multiconDrive the spindle position displays communicate directly with EC motors. Every spindle position display is connected to the corresponding motor by a separate cable output providing the motor without delay with the signals "clockwise", "counterclockwise", "rotation speed" for switchover to high/low speed.

The spindle position display provides two keys for clockwise and counterclockwise direction used during the first editing operation. The key makes the motor moving into the requested direction. A soft touch results in a defined STEP. Thus, new spindle positions can be edited under direct visual check of the operator with an accuracy of $\pm 1/100$ mm. Shaft position parameters once set can be filed as profile in the control. The serial interface enables network of maximum 32 spindle position displays with PC or PLC.

For complete solutions N 242 memory controller as operating and memory terminal is available. Up to 100 format profiles can be stored by teach-in. The respective position parameters can be retransmitted at any time as target to the respective spindle position displays to release automatic format alignment cycles.

Accessories

Connectors and cables

Z 165.A01	Adaptor cable between cable connector M16 and female M8, 1 m
Z 165.AW1	Cable connector M16, 5-pin, less cable with integrated terminating resistor 120Ω
Z 165.B01	Female connector M16, 5-pin, less cable
Z 165.D05	Data and supply cable M16, Master to N 140, N 141, N 142, N 143, 5 m
Z 165.E01	Extention cable SPA-motor (male/female) M16, 12-pin, 1 m
Z 165.S01	Cable connector M16, 5-pin, less cable
Z 165.V01	Coupling cable with M16 - M16, 5-pin, 1 m
Z 165.V03	Coupling cable with M16 - M16, 5-pin, 3 m
Z 165.V05	Coupling cable with M16 - M16, 5-pin, 5 m
Z 165.V10	Coupling cable with M16 - M16, 5-pin, 10 m
Z 178.050	Data and supply cable, $\varnothing 5$ mm, 4 cores, shielded, on 50 m drum

Spindle position displays

Hollow shaft max. $\varnothing 25$ mm, automated format alignment

Display LCD two lines, interface RS485

N 142

Terminal assignment

SPA connector and female connector, 5-pin

Connector	Assignment
Pin 1	Sensor supply +24 V
Pin 2	Sensor supply 0 V
Pin 3	–
Pin 4	Tx/Rx+, RS485
Pin 5	Tx/Rx-, RS485

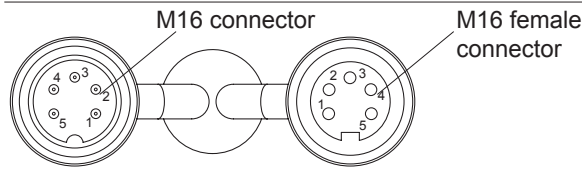

Motor connector, 12-pin

Connector	Assignment
Pin A	–
Pin B	Motor left
Pin C	Motor right
Pin D	Speed
Pin E	–
Pin F	Key 1 external
Pin G	Key 2 external
Pin H	–
Pin J	–
Pin K	Error signal
Pin L	Speed
Pin M	GND



Circuit diagram

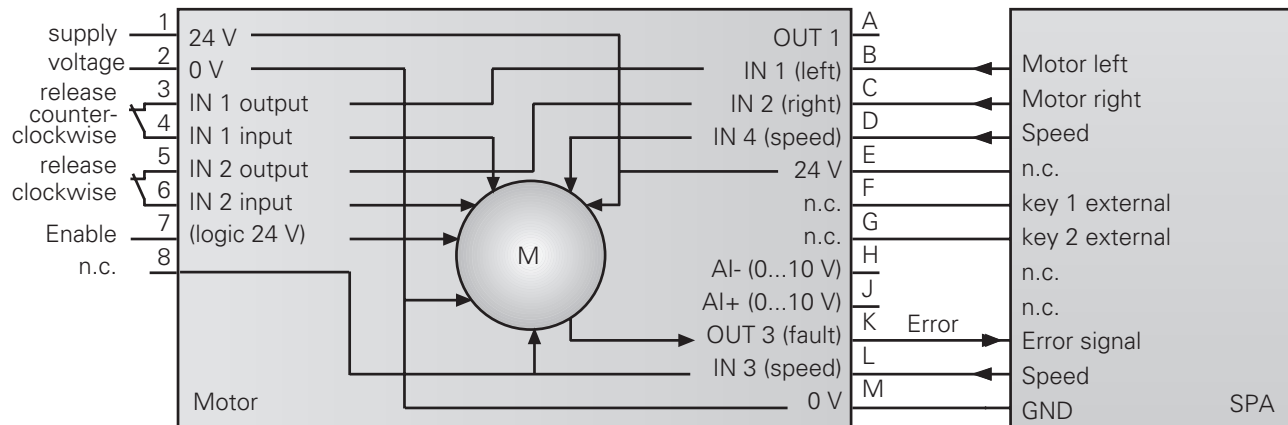

Spindle position displays

Hollow shaft max. $\varnothing 25$ mm, automated format alignment
 Display LCD two lines, interface RS485

N 142

Dimensions

