

Spindle position displays

Hollow shaft max. $\varnothing 14$ mm, manual format alignment

Display LCD two lines, interface RS485

N 150



N 150 with connector output

Features

- Manual format alignment
- Hollow shaft max. $\varnothing 14$ mm
- Resolution: 1440 steps/revolution ± 4096 revolutions
- Display: LCD backlit, two lines
- Absolute multiturn measuring system
- Actual value and target display
- Interface RS485

Technical data - electrical ratings

Voltage supply	24 VDC ± 10 %
Current consumption	≤ 30 mA
Display	LCD, 7-segment display, 2-lines, backlit
Measuring principle	Absolute multiturn measuring system
Measuring range	-99.99...+999.99 mm -9.999...+99.999 inch
Steps per turn	1440
Number of turns	4096 / 12 bit
Spindle pitch	≤ 14 mm
Interface	RS485 (ASCII protocol)
Data memory	Parameter buffer: EEPROM Current value buffer: >10 years by integrated 3 V lithium battery
Programmable parameters	Display position horizontal/vertical Measuring unit mm/inch Spindle pitch Counting direction Spindle tolerance Positioning direction Direction arrows Tolerance window Round up/down
Standard DIN EN 61010-1	Protection class II Overvoltage category II Pollution degree 2
Emitted interference	DIN EN 61000-6-3
Interference immunity	DIN EN 61000-6-2
Approval	UL approval / E63076

Technical data - mechanical design

Shaft	$\varnothing 14$ mm hollow shaft
Operating speed	≤ 600 rpm (short-term)
Protection DIN EN 60529	IP 65
Operating temperature	-10...+50 °C
Storing temperature	-20...+70 °C
Relative humidity	80 % non-condensing
Torque support	Torque pin provided at housing
Connection	- Male/female connector M8, 4-pin - Cable output (30/15 cm) with male/female connector M8, 4-pin
Housing type	Surface-mount with hollow shaft
Dimensions W x H x L	37 x 75 x 45 mm
Mounting	Surface-mount with hollow shaft
Weight approx.	120 g
Material	Polyamide black, UL 94V-0

Spindle position displays

Hollow shaft max. $\varnothing 14$ mm, manual format alignment

Display LCD two lines, interface RS485

N 150

Part number

N 150. **1** **3** **A** **01**

					<u>Hollow shaft</u>
				A	Hollow shaft $\varnothing 14$ mm
					<u>Display</u>
				A	Inclined
				B	Horizontal at front
					<u>Voltage supply</u>
			3		24 VDC
					<u>Connection</u>
			0		Connector output M8
			1		Cable output M8
					<u>Interface</u>
			1		RS485

Description

N 150 spindle position display supports the editing engineer in manual spindle positioning. The principal benefits of the new electronic spindle position display are saving time in machine setup and editing as well as eliminating errors when aligning formats to new position values. The absolute measuring system captures any change in position even in powerless state. The backlit LCD display provides the editing engineer with all necessary information for efficient editing of new spindle positions. The two-line display shows both current value and target. A little arrow signalizes the editing engineer the direction the spindle must be turned to get to the new position.

RS485 serial interface enables network of maximum 32 spindle position displays to PC or PLC.

For complete solutions also memory controllers serving as decentralized operating and memory terminals are available. Up to 100 format profiles can be stored by teach-in. Upon request the desired profile is recalled upon pressing a button and retransmitted to every spindle position display and shown as target.

Accessories

Connectors and cables

Z 178.A01	Adaptor cable between cable connector M8 and female M16, 1 m
Z 178.AW1	Cable connector M8, 4-pin, less cable with integrated terminating resistor 120 Ω
Z 178.B01	Female connector M8, 4-pin, less cable
Z 178.D05	Data and supply cable M8, Master to N 150 and N 155, 5 m
Z 178.S01	Cable connector M8, 4-pin, less cable
Z 178.V01	Coupling cable with M8 - M8, 1 m cable
Z 178.V03	Coupling cable with M8 - M8, 3 m cable
Z 178.V05	Coupling cable with M8 - M8, 5 m cable
Z 178.V10	Coupling cable with M8 - M8, 10 m cable
Z 178.050	Data and supply cable, $\varnothing 5$ mm, 4 cores, shielded, on 50 m drum

Spindle position displays

Hollow shaft max. $\varnothing 14$ mm, manual format alignment

Display LCD two lines, interface RS485

N 150

Terminal assignment

Connector	Assignment
Pin 1	Tx/Rx-, RS485
Pin 2	Tx/Rx+, RS485
Pin 3	Sensor supply +24 V
Pin 4	Sensor supply 0 V

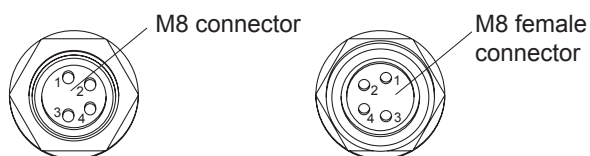

Dimensions

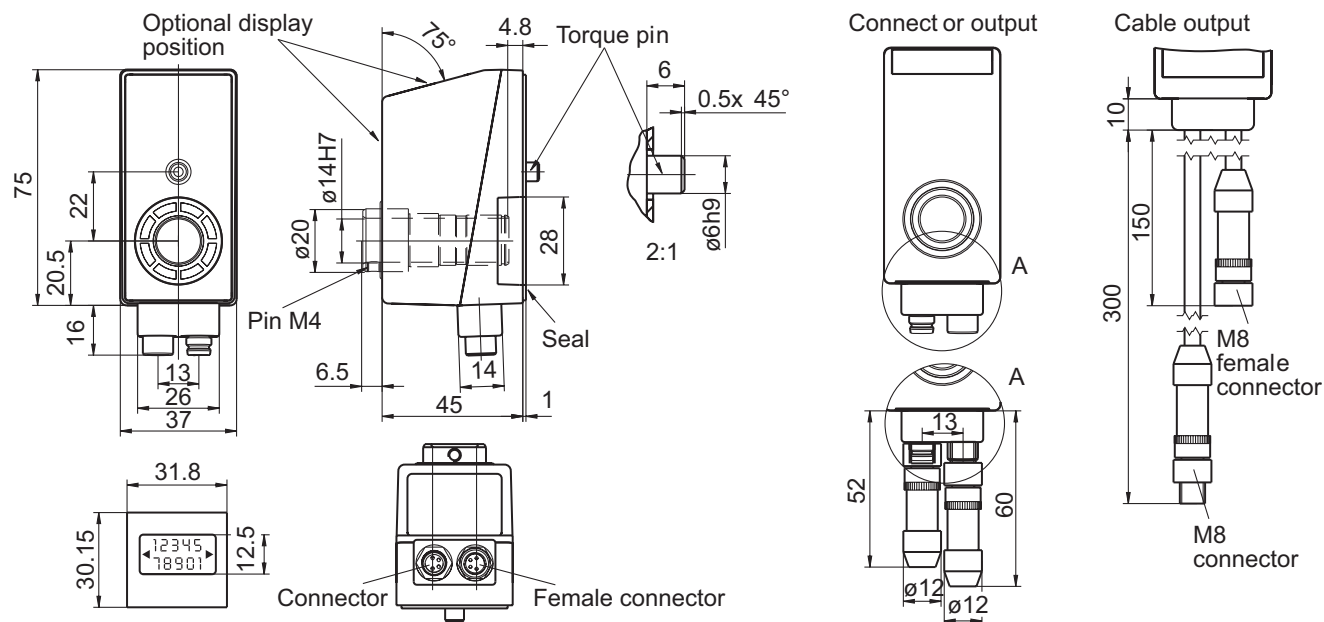

Spindle position displays

Hollow shaft max. $\varnothing 14$ mm, manual format alignment
Display LCD two lines, interface RS485

N 150
