

Absolute encoders - bus interfaces

Shaft with clamping or synchro flange

Optical multiturn encoders 13 bit ST / 16 bit MT, DeviceNet

GXP8W - DeviceNet



GXP8W with clamping flange

Features

- Encoder multiturn / DeviceNet
- Optical sensing
- Resolution: singleturn 13 bit, multiturn 16 bit
- Clamping or synchro flange
- High resistance to shock and vibrations
- LED status display
- Permanent check of code continuity

Technical data - electrical ratings

Voltage supply	10...30 VDC
Reverse polarity protection	Yes
Consumption w/o load	≤50 mA (24 VDC)
Initializing time (typ.)	250 ms after power on
Interface	DeviceNet
Function	Multiturn
Transmission rate	125...500 kBaud
Profile conformity	Device Profile Encoder V 1.0
Operating mode	I/O-Polling, Cyclic, Change of State
Identifier	11 bit
Steps per turn	8192 / 13 bit
Number of turns	65536 / 16 bit
Absolute accuracy	±0.025 °
Sensing method	Optical
Code	Binary
Code sequence	CW default, programmable
Output circuit	CAN bus standard ISO / DIS 11898
Interference immunity	DIN EN 61000-6-2
Emitted interference	DIN EN 61000-6-4
Programmable parameters	Operating modes Total resolution Preset Scaling
Diagnostic functions	Position or parameter error Multiturn sensing
Status indicator	DUO-LED integrated in housing
Approval	UL approval / E63076

Technical data - mechanical design

Housing	ø58 mm
Shaft	ø10 mm (clamping flange) ø6 mm (synchro flange)
Flange	Clamping or synchro flange
Protection DIN EN 60529	IP 54 without shaft seal IP 65 with shaft seal
Operating speed	≤10000 rpm (mechanical) ≤6000 rpm (electric)
Starting torque	≤0.015 Nm IP 54 ≤0.03 Nm IP 65
Rotor moment of inertia	20 gcm ²
Admitted shaft load	≤20 N axial ≤40 N radial
Materials	Housing: steel Flange: aluminium
Operating temperature	-25...+85 °C -40...+85 °C (optional)
Relative humidity	95 % non-condensing
Resistance	DIN EN 60068-2-6 Vibration 10 g, 16-2000 Hz DIN EN 60068-2-27 Shock 200 g, 6 ms
Weight approx.	350 g
Connection	Connector

Absolute encoders - bus interfaces

Shaft with clamping or synchro flange

Optical multiturn encoders 13 bit ST / 16 bit MT, DeviceNet

GXP8W - DeviceNet

Part number

GXP8W.		20	M1	10
				Interface
				10 DeviceNet
				Connection
			M1	Connector M12, 5-pin, radial
				Voltage supply
		20		10...30 VDC
				Flange / Shaft
	0			Clamping flange / \varnothing 10 mm IP 54
	A			Clamping flange / \varnothing 10 mm IP 65
	1			Synchro flange / \varnothing 6 mm IP 54
	B			Synchro flange / \varnothing 6 mm IP 65

Accessories

Connectors and cables

Z 180.003	Female connector M12, 5-pin, A-coded, 2 m cable
Z 180.005	Female connector M12, 5-pin, A-coded, 5 m cable
Z 180.007	Female connector M12, 5-pin, A-coded, 10 m cable

Mounting accessories

Z 119.006	Eccentric fixing, single
Z 119.013	Adaptor plate for clamping flange for modification into synchro flange
Z 119.015	Mounting adaptor for synchro flange
Z 119.017	Mounting angle for clamping flange
Z 119.035	Bearing flange for encoders with synchro flange

DeviceNet features

Bus protocol	DeviceNet
Device profiles	Device Profile for Encoders V 1.0
Operating mode	I/O-Polling Cyclic Change of State
Preset	This parameter is for setting the encoder to a requested position value assigned to a defined shaft position of the system. The offset between the encoder zero point and the mechanical zero point is stored in the encoder.
Rotating direction	This parameter is for defining the rotating direction in which there have to be ascending or descending position values.
Scaling	Parameterizing of steps per revolution and of the total resolution.
Diagnosis	The encoder supports the following error warnings: - Position and parameter error - Lithium battery voltage control (Multiturn)
Default	125 kbit/s, Mac ID 63

Absolute encoders - bus interfaces

Shaft with clamping or synchro flange

Optical multiturn encoders 13 bit ST / 16 bit MT, DeviceNet

GXP8W - DeviceNet

Terminal significance

UB	Encoder voltage supply.
GND B	Encoder ground connection relating to UB.
CAN_L	CAN bus signal (dominant Low)
CAN_H	CAN bus signal (dominant High)
DRAIN	Shield connection. Internally on housing by RC circuit.

Terminal assignment

Connector	Assignment
Pin 1	DRAIN
Pin 2	UB
Pin 3	GND
Pin 4	CAN_H
Pin 5	CAN_L

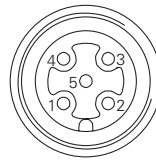

Absolute encoders - bus interfaces

Shaft with clamping or synchro flange
Optical multiturn encoders 13 bit ST / 16 bit MT, DeviceNet

GXP8W - DeviceNet

Dimensions

GXP8W clamping flange

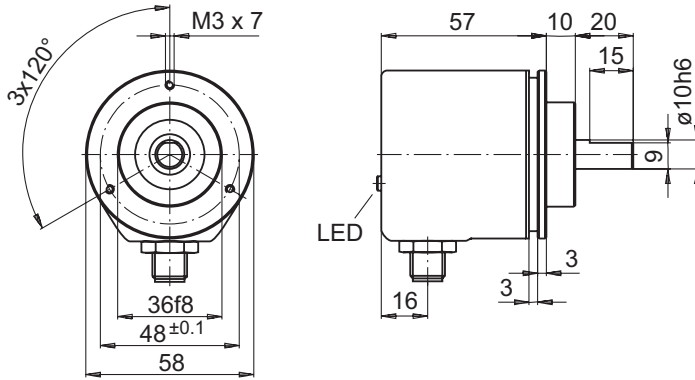

GXP8W synchro flange

