

Absolute encoders - bus interfaces

Shaft with clamping or synchro flange

Optical multiturn encoders 13 bit ST / 16 bit MT, CANopen

GXP5W - CANopen



GXP5W with clamping flange

Features

- Encoder multiturn / CANopen
- Optical sensing
- Resolution: singleturn 13 bit, multiturn 16 bit
- Clamping or synchro flange
- LED status display
- CANopen Profile CIA DSP 406
- CANopen Profile CIA DSP 417 Lift Control System
- Permanent check of code continuity

Technical data - electrical ratings

Voltage supply	10...30 VDC
Reverse polarity protection	Yes
Consumption w/o load	≤50 mA (24 VDC)
Initializing time (typ.)	250 ms after power on
Interface	CANopen
Function	Multiturn
Transmission rate	10...1000 kBaud
Profile conformity	CANopen CIA DSP 406 V 3.0 CANopen CIA DSP 417 Lift
Operating mode	Event-triggered / Time-triggered Remotely-requested Sync (cyclic) / Sync (acyclic)
Identifier	11 bit
Steps per turn	8192 / 13 bit
Number of turns	65536 / 16 bit
Absolute accuracy	±0.025 °
Sensing method	Optical
Code	Binary
Code sequence	CW/CCW programmable
Output circuit	CAN bus standard ISO / DIS 11898
Interference immunity	DIN EN 61000-6-2
Emitted interference	DIN EN 61000-6-4
Programmable parameters	Operating modes Total resolution Scaling Rotation speed monitoring
Diagnostic functions	Position or parameter error Multiturn sensing
Status indicator	DUO-LED integrated in housing
Approval	UL approval / E63076

Technical data - mechanical design

Housing	ø58 mm
Shaft	ø10 mm (clamping flange) ø6 mm (synchro flange)
Flange	Clamping or synchro flange
Protection DIN EN 60529	IP 54 without shaft seal IP 65 with shaft seal
Operating speed	≤10000 rpm (mechanical) ≤6000 rpm (electric)
Starting torque	≤0.015 Nm IP 54 ≤0.03 Nm IP 65
Rotor moment of inertia	20 gcm ²
Admitted shaft load	≤20 N axial ≤40 N radial
Materials	Housing: steel Flange: aluminium
Operating temperature	-25...+85 °C -40...+85 °C (optional)
Relative humidity	95 % non-condensing
Resistance	DIN EN 60068-2-6 Vibration 10 g, 16-2000 Hz DIN EN 60068-2-27 Shock 200 g, 6 ms
Weight approx.	500 g
Connection	Connector

Absolute encoders - bus interfaces

Shaft with clamping or synchro flange

Optical multiturn encoders 13 bit ST / 16 bit MT, CANopen

GXP5W - CANopen

Part number

GXP5W. 10

Interface

- 05 CANopen Lift DSP 417/
galvanically isolated
- 06 CANopen DSP 406 /
galvanically isolated
- 15 CANopen Lift DSP 417 not
galvanically isolated
- 16 CANopen DSP 406 not
galvanically isolated

Connection

- A3 Connector M23, 12-pin, radial
- D3 Connector D-SUB, 9-pin, radial
- M1 Connector M12, 5-pin, radial
- M2 2 x connector M12, 5-pin axial
- M3 2 x connector M12, 5-pin radial

Voltage supply

- 10 10...30 VDC

Flange / Shaft

- 0 Clamping flange / \varnothing 10 mm IP 54
- A Clamping flange / \varnothing 10 mm IP 65
- 1 Synchro flange / \varnothing 6 mm IP 54
- B Synchro flange / \varnothing 6 mm IP 65

Accessories

Connectors and cables

Z 148.001	Female connector M23, 12-pin, less cable
Z 148.003	Female connector M23, 12-pin, 2 m cable
Z 148.005	Female connector M23, 12-pin, 5 m cable
Z 148.007	Female connector M23, 12-pin, 10 m cable
Z 180.003	Female connector M12, 5-pin, A-coded, 2 m cable
Z 180.005	Female connector M12, 5-pin, A-coded, 5 m cable
Z 180.007	Female connector M12, 5-pin, A-coded, 10 m cable
Z 181.005	Cable connector M12, 5-pin, A-codage, 5 m cable connection M2 / M3, continuative bus

Mounting accessories

Z 119.006	Eccentric fixing, single
Z 119.013	Adaptor plate for clamping flange for modification into synchro flange
Z 119.015	Mounting adaptor for synchro flange
Z 119.017	Mounting angle for clamping flange
Z 119.035	Bearing flange for encoders with synchro flange

Absolute encoders - bus interfaces

Shaft with clamping or synchro flange

Optical multiturn encoders 13 bit ST / 16 bit MT, CANopen

GXP5W - CANopen

Terminal significance

UB	Encoder voltage supply
GND B	Encoder ground connection relating to UB
CAN_L	CAN bus signal (dominant Low)
CAN_H	CAN bus signal (dominant High)
CAN_GND	GND relating to CAN interface. Depending on model separated from GND B either by galvanic isolation or by inductive earthing.

CANopen features

Bus protocol	CANopen
Device profile	CANopen - CiA DSP 406, V 3.0 (Device Class 2, CAN 2.0B)
Operating modes	Event-triggered / Time-triggered Remotely-requested Sync (cyclic) / Sync (acyclic)
Preset	Parameter for setting the encoder to a requested position value assigned to a defined shaft position of the system. The offset of encoder zero point and mechanical zero point is stored in the encoder.
Rotating direction	Parameter for defining the rotating direction in which there have to be ascending or descending position values.
Scaling	Parameter defining the steps per turn as well as the total resolution.
Diagnosis	The encoder supports the following error warnings: - Position and parameter error - Lithium battery voltage control (Multiturn)
Node Monitoring	Heartbeat or Nodeguarding
Default	50 kbit/s, Node ID 1

Terminal assignment

Connector M12		
Connector	Core colour	Assignment
Pin 1	brown	GND B
Pin 2	white	UB
Pin 3	blue	CAN_GND
Pin 4	black	CAN_H
Pin 5	grey	CAN_L

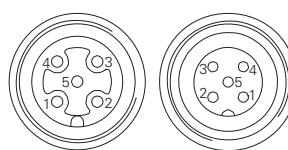

Please use cores twisted in pairs (for example CAN_H / CAN_L) for extension cables of more than 10 m length.

Connector D-SUB

Connector	Assignment
Pin 1	–
Pin 2	CAN_L
Pin 3	CAN_GND
Pin 4	–
Pin 5	–
Pin 6	GND B
Pin 7	CAN_H
Pin 8	–
Pin 9	UB

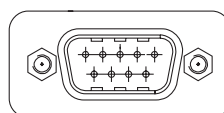

Please use cores twisted in pairs (for example CAN_H / CAN_L) for extension cables of more than 10 m length.

Connector M23

Connector	Core colour	Assignment
Pin 1	brown/green	UB
Pin 2	white/green	GND B
Pin 3	pink	CAN_L
Pin 4	grey	CAN_H
Pin 5	white	CAN_GND
Pin 6-12	–	–

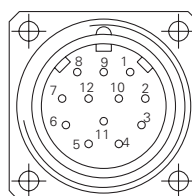

Please use cores twisted in pairs (for example CAN_H / CAN_L) for extension cables of more than 10 m length.

Absolute encoders - bus interfaces

Shaft with clamping or synchro flange

Optical multiturn encoders 13 bit ST / 16 bit MT, CANopen

GXP5W - CANopen

Dimensions

GXP5W clamping flange and connector M23

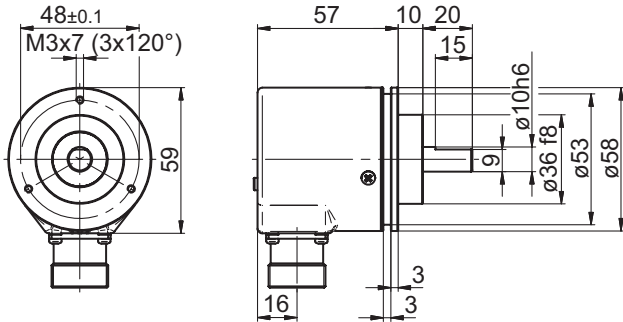

GXP5W clamping flange and connector M12

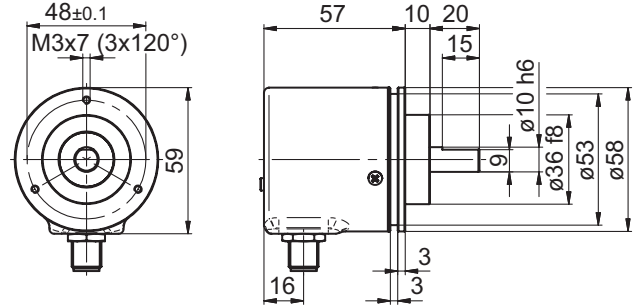

GXP5W clamping flange and D-SUB

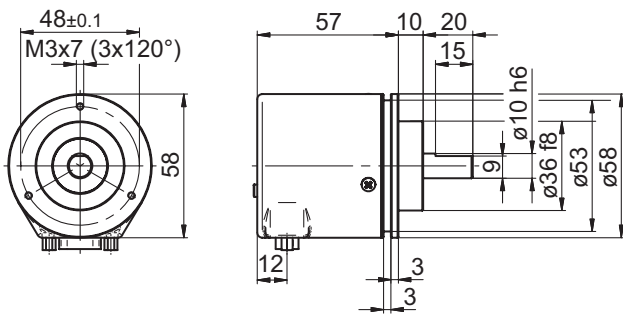

GXP5W clamping flange, 2 x connector M12, radial

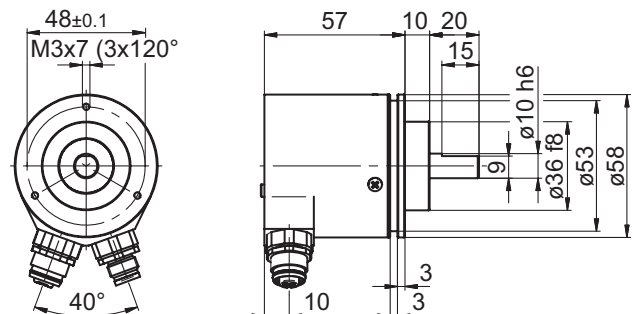

GXP5W clamping flange, 2 x connector M12, axial

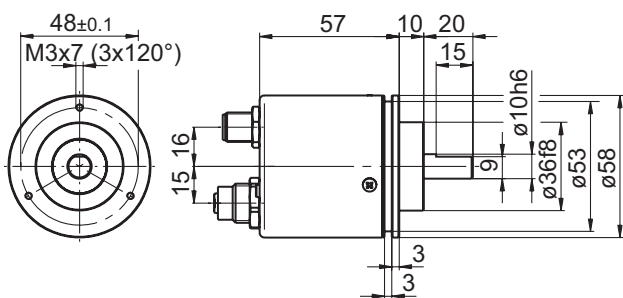

GXP5W connector dimensions

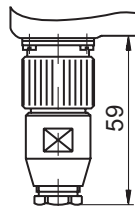

GXP5W synchro flange

